



201 Grandin Road
Maineville, Ohio 45039
(513) 677-0500

BavisAIR APS Pneumatic System

Installation and Service Manual

Copyright 2017 E. F. Bavis & Associates, Inc.
All Right Reserved

Revised: 03/20/2017
PN: 00710021

Table of Contents

Important Safety Instructions.....	1
Overview.....	2
BavisAIR Pneumatic System Operation.....	3, 4, 5, 6, 7
Installation.....	8
Teller Wall Standoff	9
Power Connection.....	11
Connecting Cable Wiring	11
Horizontal Tube Support.....	11
Anti-static Grounding Harness	12
Startup.....	13
Switch Settings.....	14
Troubleshooting the BavisAIR Pneumatic System	15
APS Customer Blower Wiring Diagram.....	16
APS Customer Wiring Diagram	17
APS Teller Wiring Diagram	18
Typical System Layout	19
BavisAIR Shipping Manifest.....	20
Optional Additional Parts	21
APS Final Inspection List.....	23

Important Safety Instructions

1. READ THESE INSTRUCTIONS.
 2. KEEP THESE INSTRUCTIONS.
 3. HEED ALL WARNINGS.
 4. FOLLOW ALL INSTRUCTIONS.
 5. DO NOT CLEAN THIS APPARATUS WITH A WATER SPRAY OR THE LIKE.
 6. DO NOT BLOCK ANY VENTILATION OPENINGS. INSTALL IN ACCORDANCE WITH THE MANUFACTURER'S INSTRUCTIONS.
 7. DO NOT INSTALL NEAR ANY HEAT SOURCES SUCH AS RADIATORS, HEAT REGISTERS, STOVES OR OTHER APPARATUS THAT PRODUCES HEAT.
 8. ONLY USE ATTACHMENTS / ACCESSORIES SPECIFIED BY THE MANUFACTURER.
 9. TURN THE POWER SWITCH TO THE "OFF" POSITION WHEN THE APPARATUS IS NOT IN USE AND BEFORE SERVICING.
 10. REFER ALL SERVICING TO QUALIFIED SERVICE PERSONNEL. SERVICING IS REQUIRED WHEN THE APPARATUS HAS BEEN DAMAGED IN ANY WAY, SUCH AS LIQUID HAS BEEN SPILLED OR OBJECTS FALLEN INTO THE APPARATUS, THE APPRATUS DOES NOT OPERATE NORMALLY.
-

Grounding Instructions

1. THIS MACHINE MUST BE CONNECTED TO A GROUNDED METAL, PERMANENT WIRING SYSTEM; OR AN EQUIPMENT-GROUNDING CONDUCTOR MUST BE RUN WITH THE CIRCUIT CONDUCTORS AND CONNECTED TO THE EQUIPMENT-GROUNDING TERMINAL OR LEAD ON THE CONVEYOR.
2. DANGER-CHECK WITH A QUALIFIED ELECTRICIAN OR SERVICEMAN IF THE GROUNDING INSTRUCTIONS ARE NOT COMPLETELY UNDERSTOOD, OR IF IN THE DOUBT AS TO WHETHER THE APPARATUS IS PROPERLY GROUNDED.

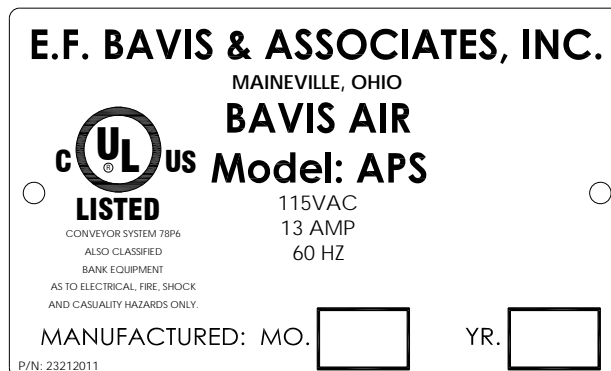

BavisAIR Pneumatic System

Overview

The BavisAIR system is a pneumatic tube system kit intended for the conveyance of currency and documents between customers and tellers at drive-thru banking lanes. Both the teller and customer units have powder coat finished aluminum trims. The 4-1/2" tubing is not supplied. The system can be shipped configured for steel or PVC tubing in the radius and horizontal sections of the machine. The vertical sections of the machine are always PVC.

The BavisAIR system must be run in an overhead configuration. It was not designed to accommodate "Downsend" configurations. If there is a need for this type of configuration at a given site, we suggest that you consider a product from our Autoveyor™ product line. Please contact us for more details on this product line.

In order to provide the greatest speed, safety of operation and cold weather performance, the BavisAIR System uses a powered door at both ends of the system. There are safety mechanisms at each door. In the event the safety mechanism is activated after the send switch is pressed the transaction is cancelled and the door reverses to the open position.

The customer audio components, speaker, microphone and call button are supplied with the system. The audio wiring is ran by others either overhead or underground. For more information see the *TYPICAL SYSTEM LAYOUT* section of this manual.

The weight capacity of the system is rated at two pounds, which is equivalent to two rolls of quarters.

This system is intrinsically safe in that the mechanical power levels at the moving parts (teller and customer door) are below 15 lbs. of force. The electrical power levels at all locations other than the *Blower Assemblies* are intrinsically safe in that they are at NEC Class II levels (24V 100 VA) or lower. For more information see the *POWER CONNECTION* section of this manual.

The BavisAIR System has been reviewed by a third party for safety and suitability for the given application. Please review the label applied to the machine for details concerning this review. The system is UL Listed for use as a conveyor and Classified for banking use. The APS system design is protected by US patents 7,264,421 & 7,234,898.

Each part in the kit contains a label with the part name and number attached to it. Please read over this manual before installation to familiarize yourself with the different components and where they are used in the system. For more information see the *TYPICAL SYSTEM LAYOUT* section of this manual.

A schematic of installed BavisAIR System identifying major components by part number follows.

If there are questions about any of the following, contact the Technical Service Department at (513) 677-0500.

BavisAIR Pneumatic System Operation

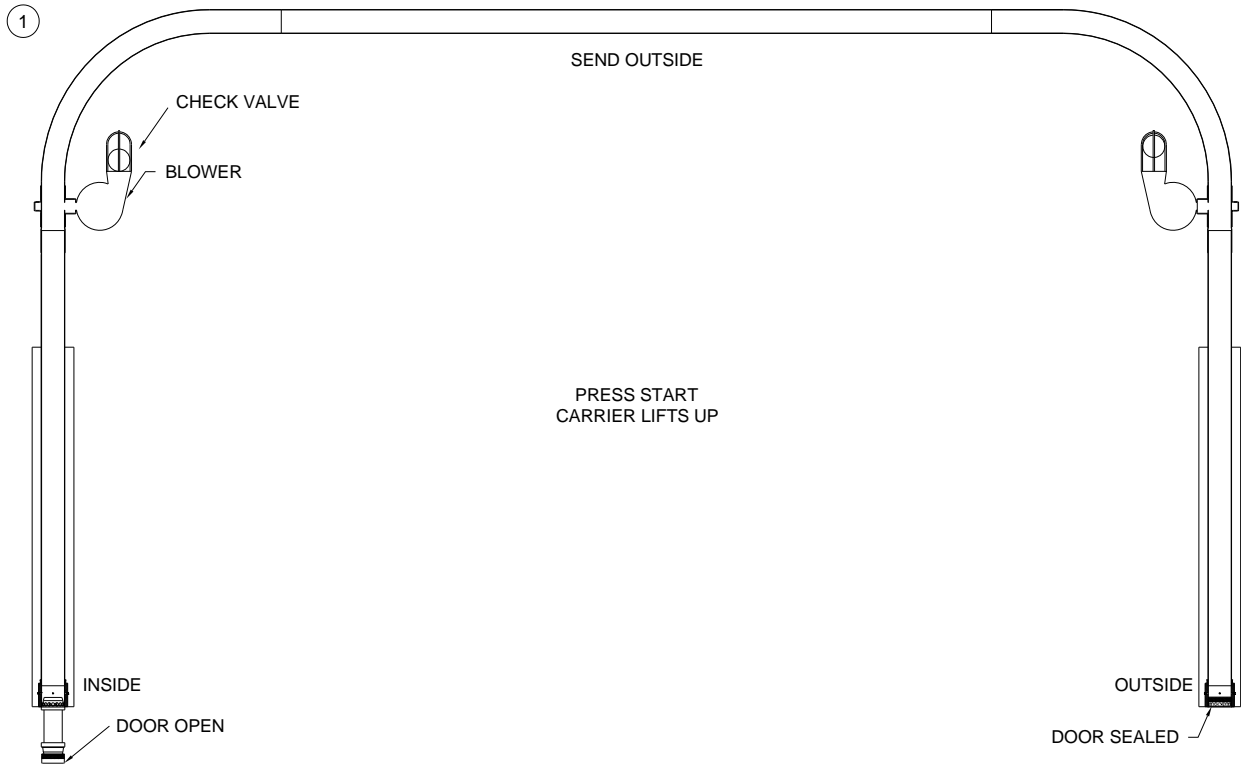

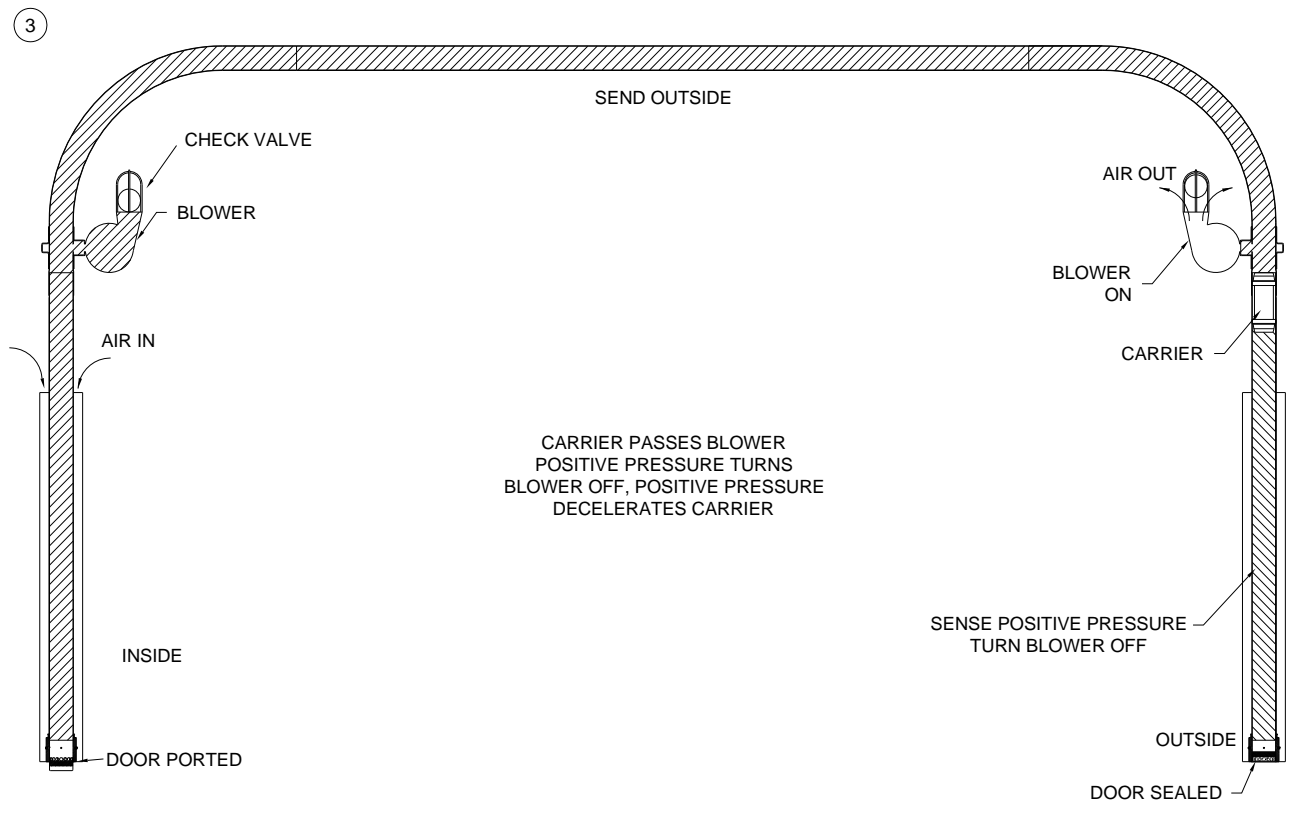
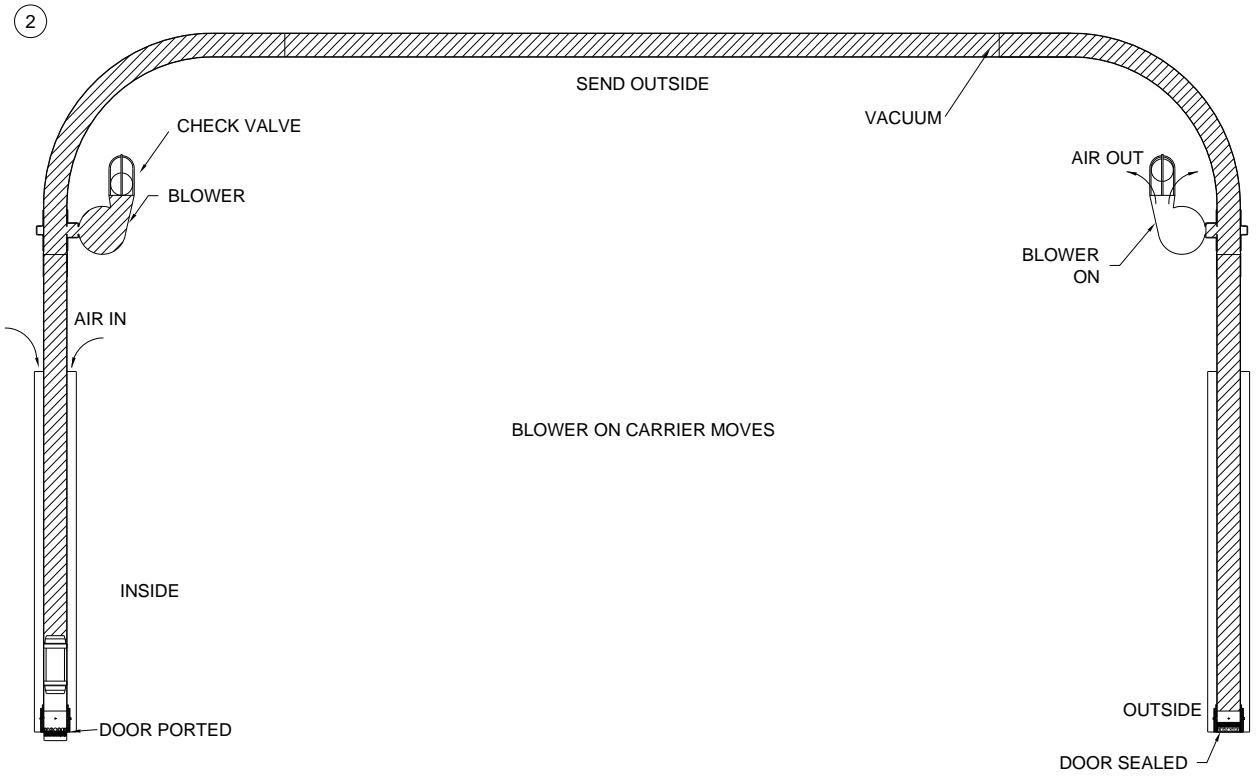

4

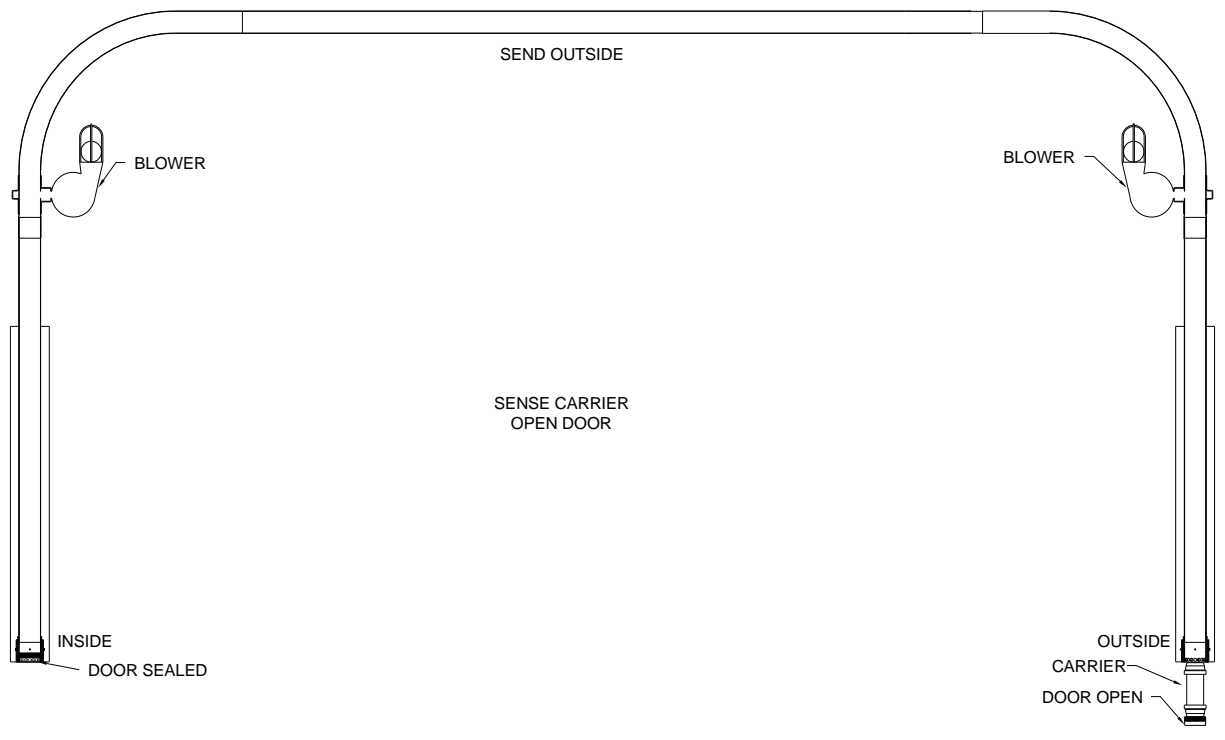

5

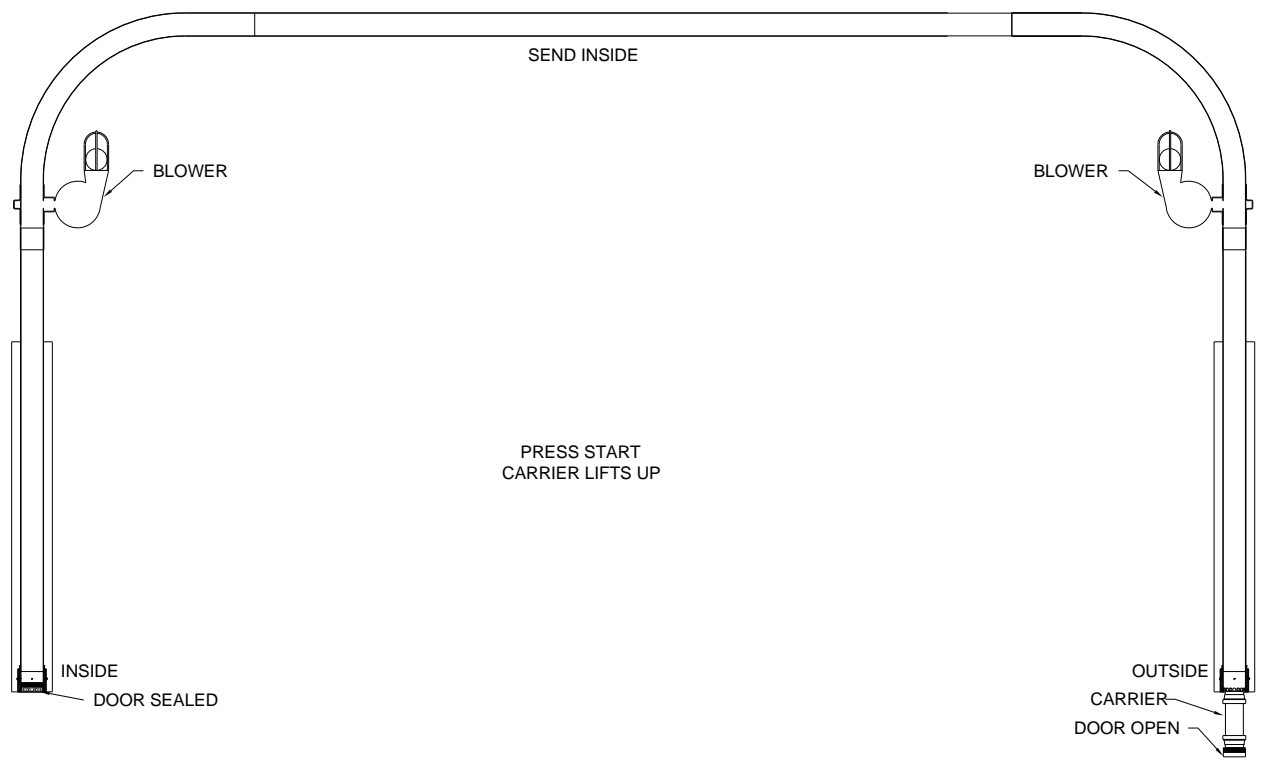

6

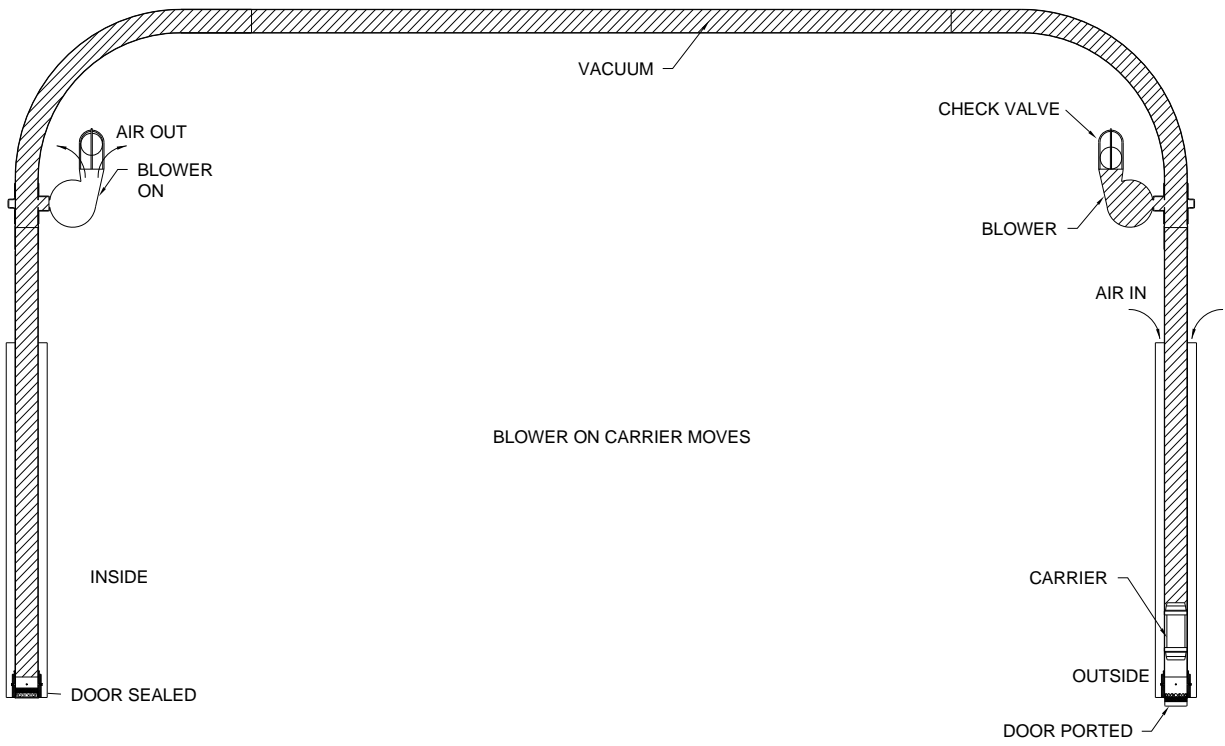

7

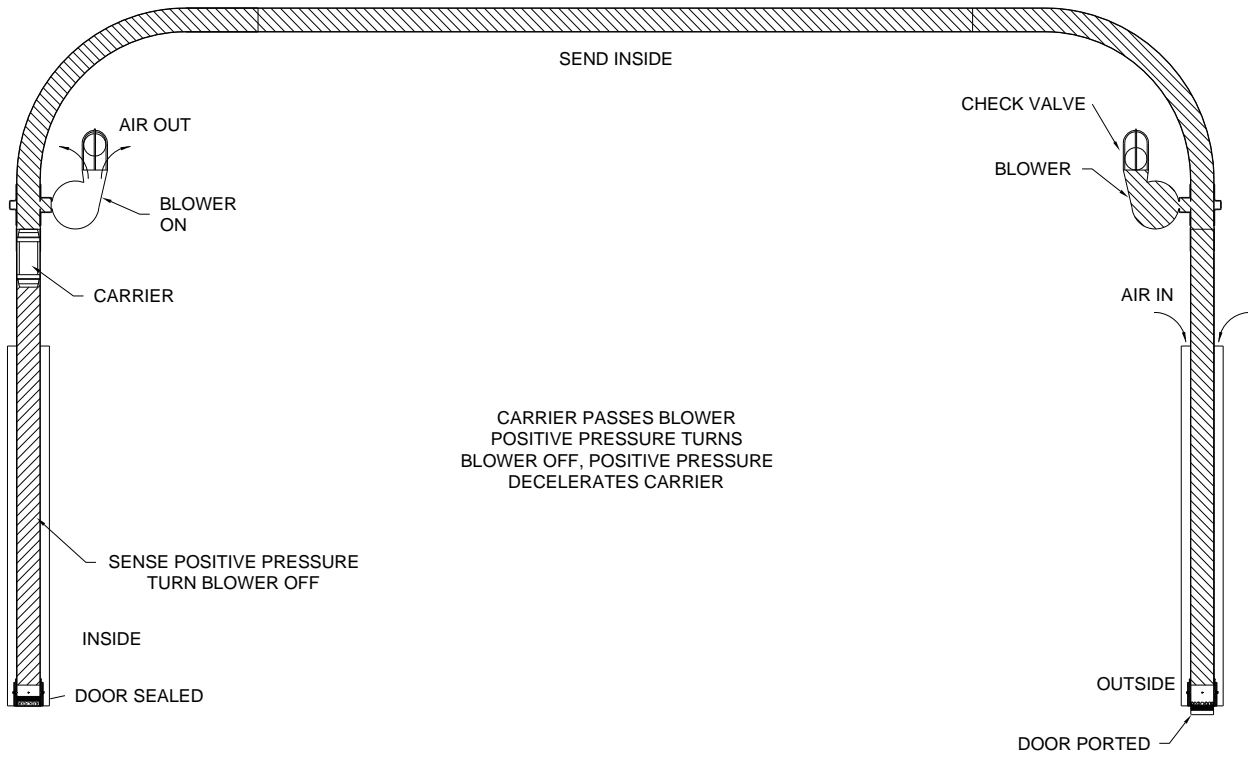

8

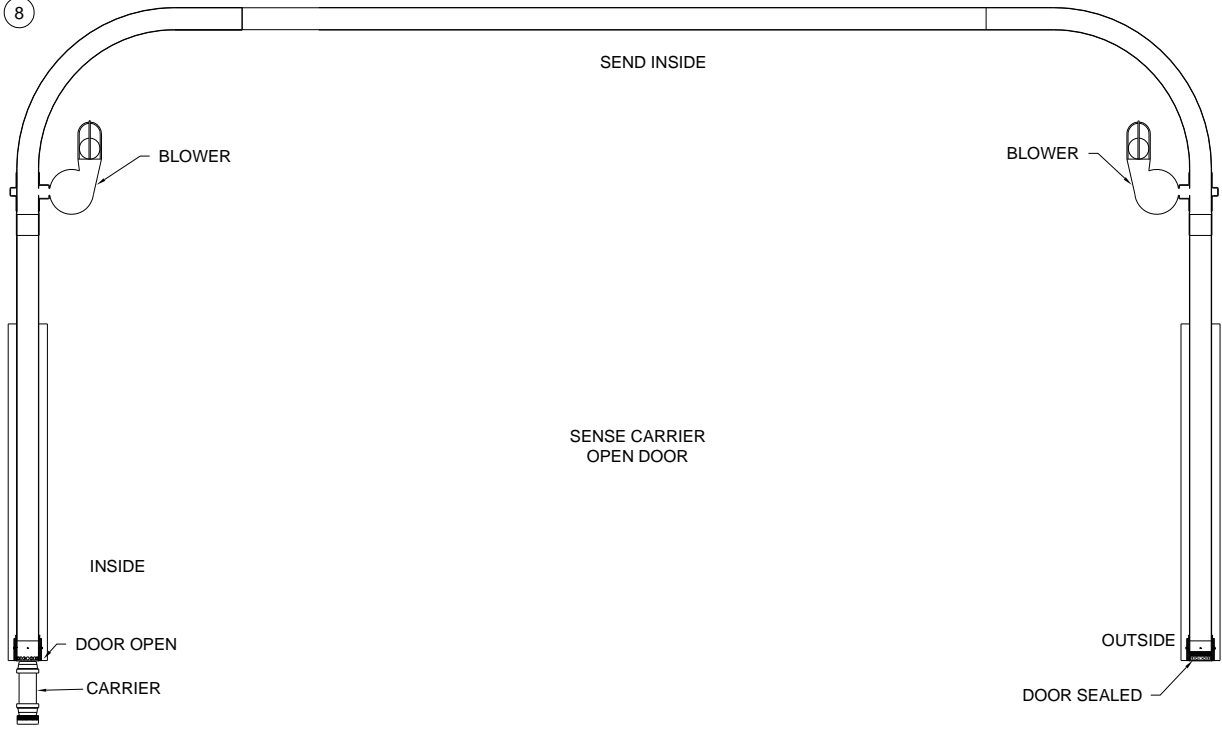

Installation

Teller Installation:

The finish trim of the teller unit comes from the factory approximately 6' tall. The trim can be cut shorter.

To cut the trim shorter first remove the top cap by loosening the hose clamp that secures the tube to the cap and then remove the screws holding the top cap to the trim. Cut the trim to length and deburr all of the edges. Replace the top cap. Drill 7/64" pilot holes and reinstall the screws into the trim. Replace and tighten the hose clamp that secures the tube to the top cap.

To remove or install the tubing in the teller unit remove the lids. Note that the lower lid is secured with one screw on the bottom of the teller unit. **CAUTION: *The teller control panel wiring is attached to the lid and the teller unit. Do not drop the lid, the wiring will be damaged. Unplug the switch wires from the harness. All of the switch wiring is color coded.*** The tubing is inserted through the top cap and into the carrier receiver. Make sure there are no burrs on the tubing. A hose clamp is used to secure the tubing at the top cap. The tubing is a slip fit into the cast aluminum carrier receiver. . The teller unit should be installed plumb, and anchored securely from above the ceiling using either the eye-bolts provided with drop ceiling wire or threaded rod, then stabilized to the wall with the bracket provided. (NOTE: The Wall Standoff Bracket is meant to stabilize the Teller unit and can not support its weight.). For dimensions see the *TELLER VIEW* of the *TYPICAL SYSTEM LAYOUT* section of this manual.

A wall standoff is shipped with each and every Pneumatic System. Its purpose is to stabilize the Teller end of the Pneumatic System, not to support its weight. The standoff is mounted to the wall, and secured to the Teller skin with self-tapping screws, (see illustration on next page).

Optional ceiling trim rings are available.

Teller Wall Standoff

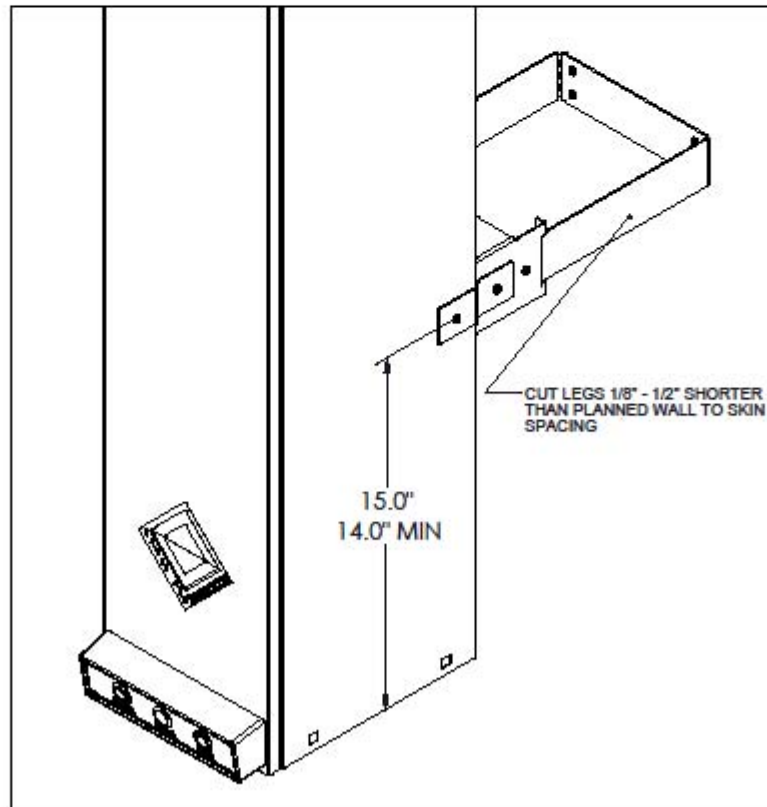
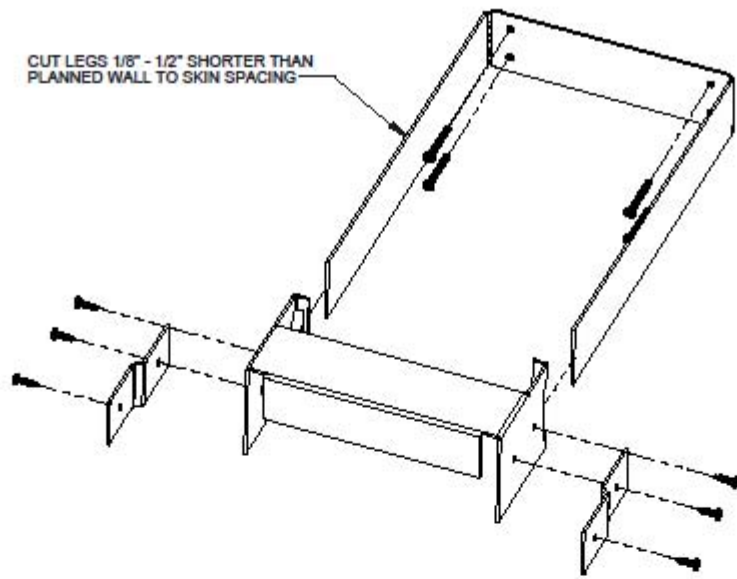

Revised 1/18/10

Customer Installation:

The finish trim of the customer unit comes from the factory 12' tall. Note that the trim is designed for 0" island height. Remove the black base from the customer unit. Cut off only an amount equal to the island height from the bottom of the trim. Mark and drill (4) 9/32" holes for the nuts and bolts that secure the black base to the bottom of the customer unit. Note that there are 1" slots in the black base which allow some adjustment for the black base.

The trim can also be cut shorter. To cut the trim shorter first remove the top cap by loosening the hose clamp that secures the tube to the cap and then remove the screws holding the top cap to the trim. Cut the trim to length and deburr all of the edges. Replace the top cap. Drill 7/64" pilot holes and reinstall the screws into the trim. Replace and tighten the hose clamp that secures the tube to the top cap.

To remove or install the tubing in the customer unit remove the lids. The tubing is inserted through the top cap and into the carrier receiver. Make sure there are no burrs on the tubing. A hose clamp secures the tubing at the top cap. The tubing is a slip fit into the cast aluminum carrier receiver. The customer unit should be installed anchored securely to the island. The customer unit should be installed plumb. For dimensions see the *TYPICAL SYSTEM LAYOUT* section of this manual.

Optional ceiling trim rings are available.

Blower Installation:

There are two blowers. The blowers are remote mounted. Caution the blowers must be installed in the correct orientation. There is a ball type one way valve on each blower discharge. Each blower is marked with **THIS END UP** and an arrow. A "Tee" is supplied for the vacuum connection to the vertical tubing below the radius tube. This "Tee" is machined to match up correctly with 4-1/2" PVC pneumatic tubing and has a 1-1/2" schedule 40 PVC pipe connection. The connections between the blower and the "Tee" can be made with trade size 1-1/2" schedule 40 PVC pipe. Four nipples that adapt 1-1/2" schedule 40 PVC pipe to 2" flexible hose are supplied as well as 7' of 2" flexible hose. Two 1-1/2" schedule 40 PVC street els are provided to allow the teller blower to be mounted inside the canopy if desired. The PVC connections should be sealed with PVC cement. Note that PVC cement and cleaner are not included with the system. The hose connections are made secure with stainless steel hose clamps that are provided.

The blower wiring for the **BavisAIR System** is connectorized. There is a cable that connects each blower assembly to the mating vertical unit. This cable has four conductors, two conductors supply 24 VAC power to the control board from the transformer in the blower assembly, one conductor is used for the signal to turn the blower on and one conductor is used for earth ground. The connector will pass through the 5/8" hole in the skin top cap. A bushing is supplied built into the cable assembly. After passing the cable and connector through the hole insert the bushing into the hole to protect the cable from the edges of the metal. Plug the cable into the mating cable on the control board.

Power Connection:

The AC Line connection is at the top of the *BLOWER ASSEMBLY*. The connection method should comply with all authorities having jurisdiction, (i.e. National, State or Local Electrical Codes). 1/2" knockouts are provided on a single gang box. Removing the cover will reveal three leads for termination.

The white wire is the neutral.

The black wire is the hot. (Single-phase 120vac, 20amp)

Green is for ground.

WARNING: To reduce the risk of shock hazard of both line voltage and static, the ground must be connected to a good earth ground.

The wiring can be enclosed in flexible metallic or nonmetallic conduit. Do not use an extension cord for permanent wiring and do not run flexible cords through or conceal in walls, ceilings and or other permanent fixtures.

Note that only blower runs at a time. Both blowers for a single lane can be connected to the same 20 amp circuit. For Lanes with multiple blowers at each end, one blower from each end can be connected to the same circuit.

Connecting Cable Wiring:

There is a CAT5 horizontal cable that connects the two boards together. This cable provides the serial communication between the two boards. This cable has a connector on each end. The horizontal cable is identical on both ends and cannot be installed backwards.

The communications cable and the anti-static grounding wire, (for lanes using PVC Tubing), should be run alongside, and secured to the horizontal tubing to reduce the induction of electrical interference into the system.

The connector will pass through the 7/8" hole in the skin top cap. A bushing is supplied built into the cable assembly. After passing the cable and connector through the hole insert the bushing into the hole to protect the cable from the edges of the metal. Plug the cable into the mating cable on the control board.

Horizontal Tubing Support:

Horizontal tubing should have a support at least every 10 feet and each support capable of holding a minimum of 20 pounds for every lane of tubing carried by it.

Anti-static Grounding Harness:

For PVC Tubing:

There is a 14 Gauge Green w/Yellow stripe wire with a ring terminal at each end that needs to be attached to each skin. This cable provides the common ground plane between the Teller and Customer stations to reduce the possibility of static discharge interfering with the electronics. The ring terminal should be secured under one of the screws for the Vent Cover at the top of each skin. (See the illustration below)

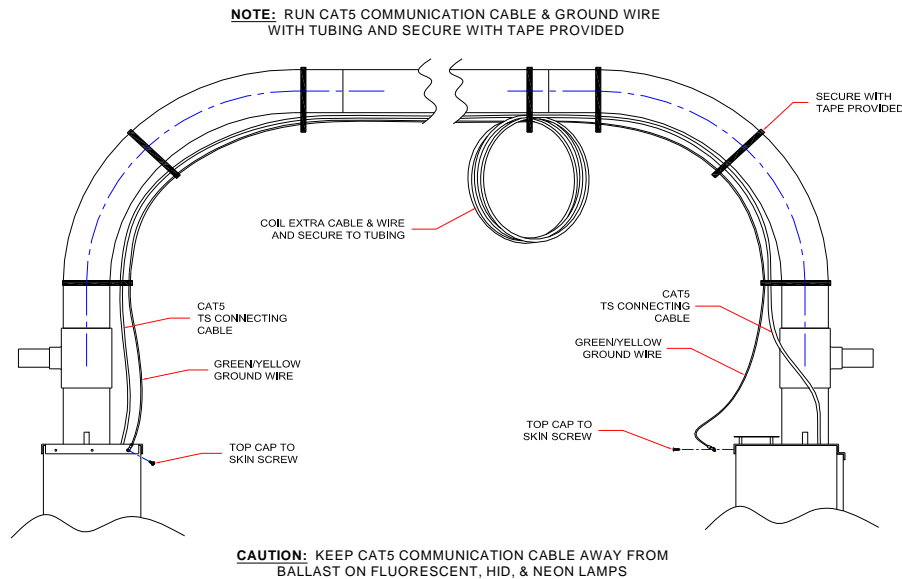

For Steel Tubing:

There are 14 Gauge Green w/Yellow stripe wires with a ring terminal at each end that need to be attached to each skin, then attached to the stud of the clamp, which you need to mount on the radius tube for each vertical. These cables provide the common ground plane between the Teller and Customer stations to reduce the possibility of static discharge interfering with the electronics. (See the illustration below)

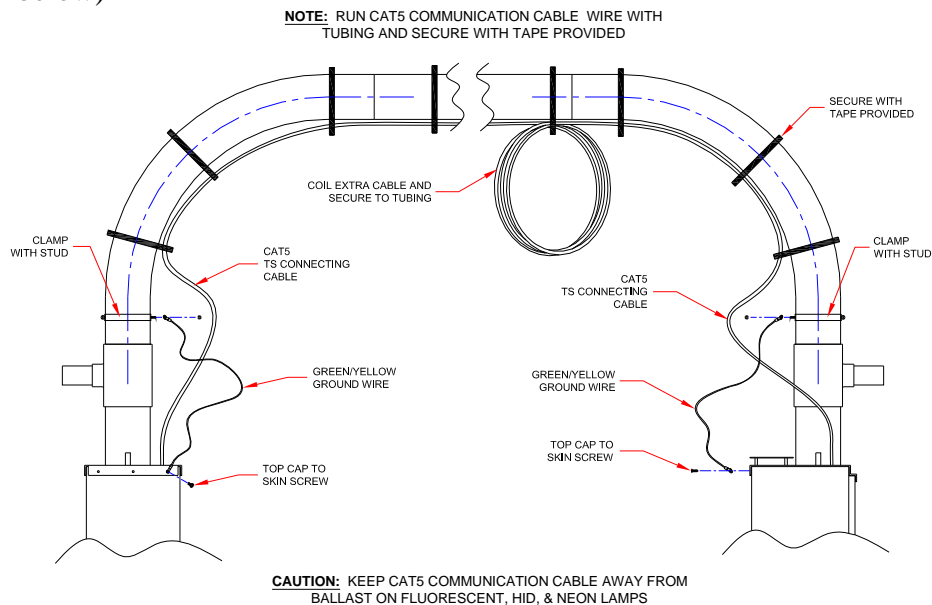

Startup:

Press the **POWER BUTTON** once. The **Green LED** in the button should come on, indicating that the unit has power. Both the teller and customer doors should open. Pressing the **POWER BUTTON** again should toggle the power off. Both the teller and customer doors should close.

With the power on and both doors open insert a **CARRIER** into the system. The door on the opposite end should close. Press the **SEND BUTTON**. The door should close to the ported position. The blower turns on. The carrier moves to the opposite end. When the carrier passes the blower the positive pressure will turn the blower off. The carrier will coast to the door plug. A photo eye system senses the presence of the carrier. The door will open. After the door is open the door on the opposite end will close to the sealed position. Note that if the pressure switch does not work the photo eye will open the door. If the photo eye does not work a timer will open the door. In the event a sensor fails the power LED will flash until the next move is made.

Reset:

In the event that the machine becomes unresponsive to the pushbuttons it is possible to reset the machine by simultaneously depressing the **SEND & RECALL BUTTONS**. This resets the processors on both the teller and customer units. The **Green LED** will turn off and both doors will run to the closed position if they are not already there. The machine will then be ready for operation.

Setting the Maximum Run Timer:

The **BavisAIR System** is equipped with a maximum run timer. This will stop the blowers in the event that a carrier gets stuck or both the pressure switch and photo eye stop working.

The procedure for doing this is as follows: Note the length of time required for a normal transaction. Remove the teller lid (be careful to not strain the switch wires). Locate adjustment pot R46 **MAXIMUM RUN TIMER**. Remove the carrier. Press the send button. Note how long the blower runs. Adjust the pot until the blower runs for approximately 10 seconds longer than the length of time required for a normal transaction. Adjusting the pot clockwise increases the time and counter clockwise decreases the time. The maximum time available is 45 seconds. The customer blower maximum run timer will also need to be set on the customer control board using the same procedure.

Error Reporting:

There is an error reporting system built into the system. Errors such as a timeout, safety mechanism operation, etc. are recorded in addition to number of cycles and blower run time. It requires optional equipment from E.F. Bavis to view or download the error log.

Revised May 30, 2008

Switch Settings

Door Test

The **BavisAIR System** is equipped with a door test feature that can be activated to cycle the door between the open, ported and closed positions. This is useful to check the unit for proper operation after service.

The procedure for doing this is as follows. Remove the teller lid or remove the customer lid and weatherproof cover. Slide the DIP switch 1 up. Press the test button. Each time the button is pressed the door moves to the next position repeating as pressed.

To turn off the door test feature, slide the DIP switch 1 down. Replace the teller lid or customer weatherproof cover and lid. Cycle the “Power” button off, and then back on to reset the board back into “run” mode.

Autocycle

The **BavisAIR System** is equipped with an autocycle feature that can be activated to run the carrier in and out. This is useful to check the unit for proper operation after installation or service.

The procedure for doing this is as follows. Recall the carrier to the inside. Remove the teller lid. Slide DIP switch #2 up. Press the test button. The system will send the carrier to the customer unit, pause for 10 seconds then return the carrier to the teller unit repeating.

To turn off the autocycle feature, press the power button on the teller control panel and turn off the unit. To resume normal operating procedure, press the power button and turn the unit on. To disable the autocycle feature slide DIP switch #2 down. Replace the teller lid. Cycle the “Power” button off, and then back on to reset the board back into “run” mode.

DEACTIVATE PRESSURE SWITCH

The up position of DIP switch 3 deactivates the pressure switch. This may be needed if there are multiple vertical sections of tube in a single system. In this configuration positive pressure is developed in the first vertical turning the blower off early. Cycle the “Power” button off, and then back on so the board will register this mode.

Board Gender

The **BavisAIR System** uses the same board on each end of the machine. The position of DIP switch 4 determines which end is the teller or customer. Note that for a machine to operate one DIP switch must be up and one down. The teller end switch must be in the down position. . Cycle the “Power” button off, and then back on so the board will register this mode.

Troubleshooting the BavisAIR Pneumatic System

This section assumes that the machine in question has been inspected for loose, damaged or missing parts, wiring, etc.

LED Diagnostics:

Power ON	Illuminates when the power button is depressed
Send (D28)	Illuminates when the send button is depressed
Recall (D31)	Illuminates when the recall button is depressed
CPU Active	Flashes indicating communication with the opposite board.
Send (D10)	Illuminates when a send move is in process.
Recall (D6)	Illuminates when a recall move is in process
Ported	Illuminates when the door is in the closed and ported position.
Sealed	Illuminates when the door is in the closed and sealed position.
Open	Illuminates when the door is in the open position.
Air	Illuminates when the pressure switch is activated by a carrier.
Safety	Illuminates when the door motor is running closed and the safety bar is activated. Note the LED will not illuminate if the motor is not running.
Blower	The blower motor is running.
Close	The door motor is running in the closed direction.
Open	The door motor is running in the open direction.
Service	The photo eye system is dirty or partially obscured.
Eye Blocked	The LED is normally on when both photo eye parts are connected, and goes off when the eye is blocked (carrier present), or the Service LED is on.

NOTHING WORKS:

Is the power LED illuminated on the control boards? (Note that there are separate control boards and power on each end of the lane). Check both circuit breakers on the blower assembly. If the circuit breakers have white showing they are tripped. Reset the breaker and check again. If the power is not on check the 115vac power coming into the machine. Check the circuit breaker in the bank or have an electrician restore power to the unit.

Is the green COM LED flashing? If the COM LED is not flashing, you can reset both processors by simultaneously pressing the SEND and RECALL buttons at the teller end. This will reset the processors on both the teller and customer units. The COM LED should then start flashing.

APS Blower Wiring Diagram

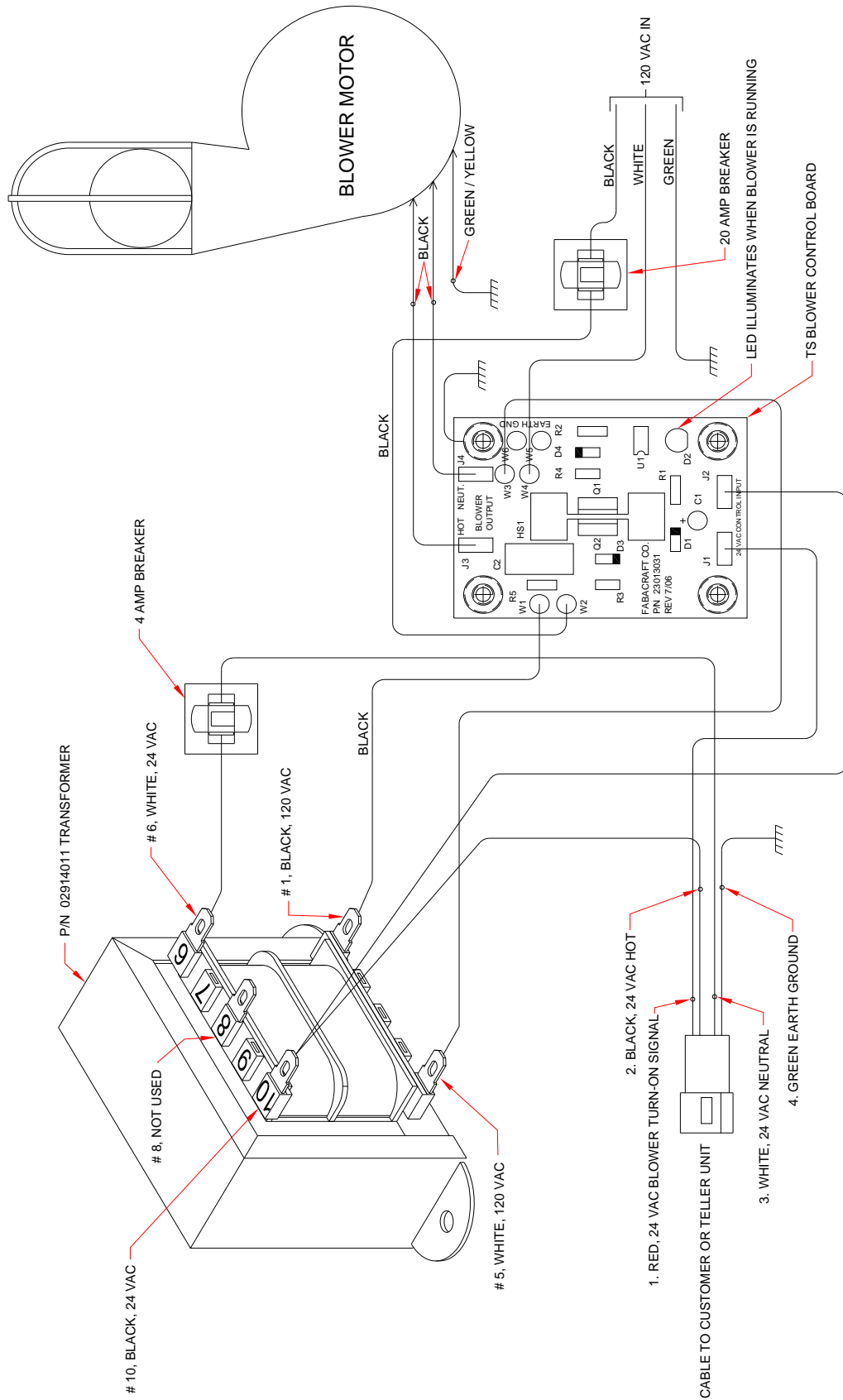

APS Teller Wiring Diagram

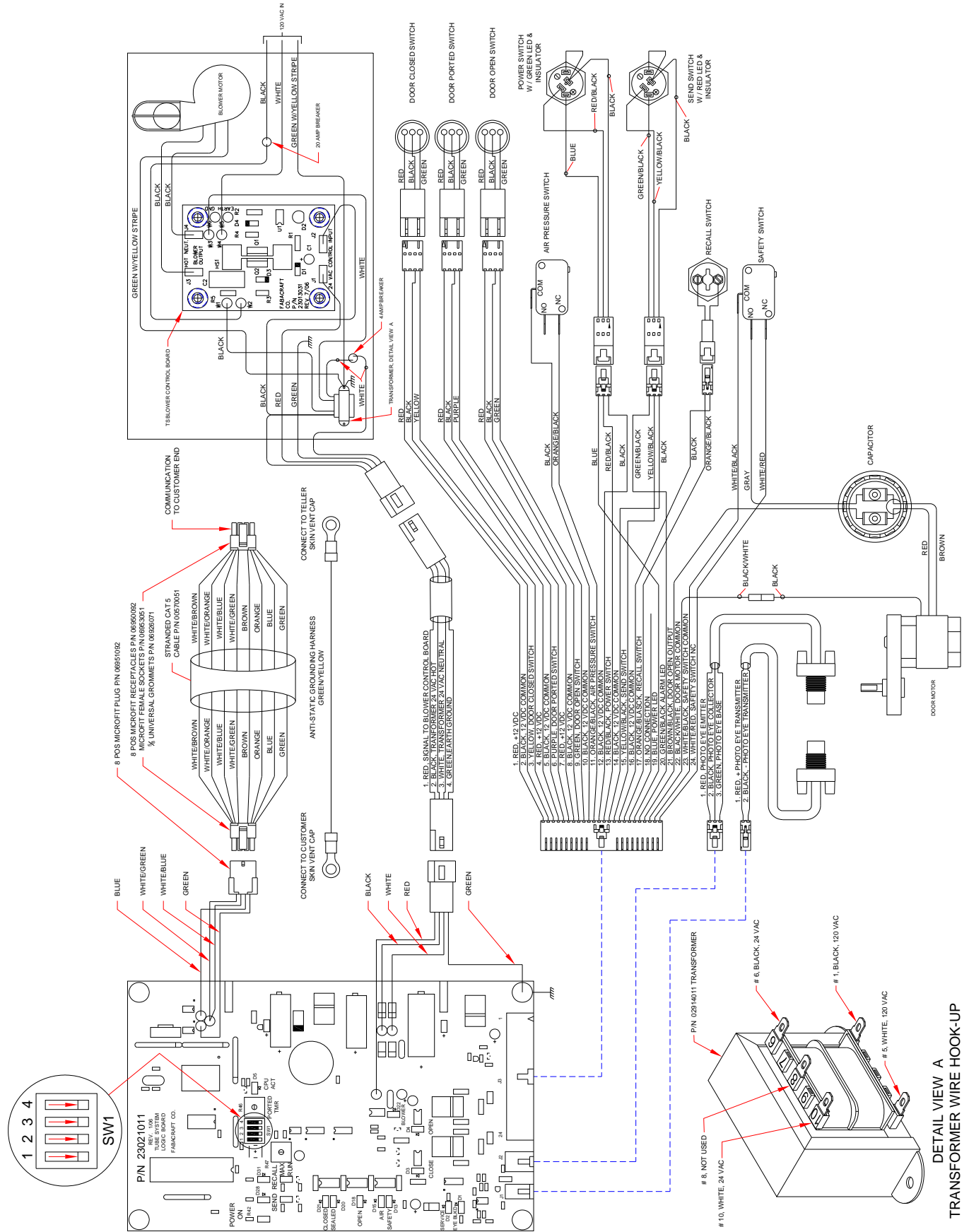

Typical System Layout

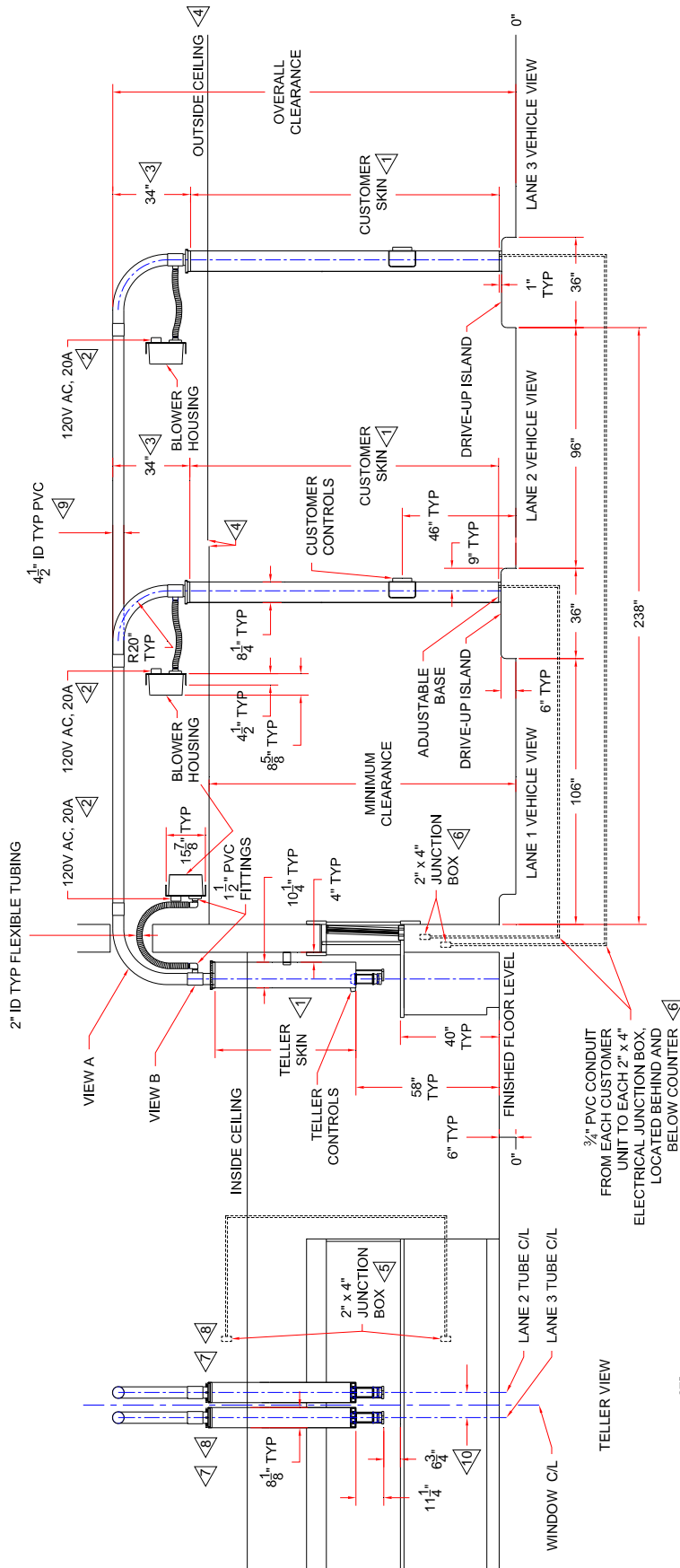

- 1 CUT TO LENGTH IN THE FIELD TO ISLAND HEIGHT.
- 2 ONE CIRCUIT PER LANE.
- 3 CAN BE SHORTER. SEE BLOWER INSTALLATION SECTION OF MANUAL.
- 4 OUTSIDE CEILING HEIGHT DIFFERENCE, LANES 2 & 3.
- 5 FOR AUDIO/VIDEO LINE CHASES RUNNING ABOVE CEILING TO BELOW COUNTER (COMMON METHOD).
- 6 FOR AUDIO/VIDEO LINE CHASES RUNNING UNDER GROUND LEVEL (ALTERNATE METHOD).
- 7 TELLER UNIT TO BE SUPPORTED BY TOP CAP (WEIGHT 60 POUNDS).
- 8 FOUR (4) 3/8" HOLES IN TOP FOR DROP CEILING WIRE OR THREADED ROD.
- 9 HORIZONTAL TUBING SHOULD HAVE A SUPPORT AT LEAST EVERY 10 FEET AND EACH SUPPORT CAPABLE OF HOLDING A MINIMUM OF 20 POUNDS FOR EVERY LANE OF TUBING CARRIED BY IT.
- 10 TELLER VERTICALS CAN BE INSTALLED WITH SKINS ABUTTING EACH OTHER.

- 1 TELLER UNIT TO BE SUPPORTED BY TOP CAP (WEIGHT 60 POUNDS).
- 2 FOUR (4) 3/8" HOLES IN TOP FOR DROP CEILING WIRE OR THREADED ROD.
- 3 HORIZONTAL TUBING SHOULD HAVE A SUPPORT AT LEAST EVERY 10 FEET AND EACH SUPPORT CAPABLE OF HOLDING A MINIMUM OF 20 POUNDS FOR EVERY LANE OF TUBING CARRIED BY IT.
- 4 TELLER VERTICALS CAN BE INSTALLED WITH SKINS ABUTTING EACH OTHER.

BavisAIR APS Shipping Manifest

23000992

<u>Qty.</u>	<u>Description</u>	<u>Part Number</u>	<u>Checked</u>
2	Blower Assembly	23002992.....	_____
1	Teller Assembly	23019992.....	_____
1	Customer Assembly	23020992.....	_____
1	Installation Accessories Consisting of:	23084992.....	_____
1	Manual.....	00710021.....	_____
1	TS Connecting Cable.....	23051011.....	_____
2	Blower Cable	23213011.....	_____
1	5" Hose Clamp	23085011.....	_____
4	2-1/2" Hose Clamp	23085021.....	_____
1	Carrier.....	23111011.....	_____
1	Teller Wall Mount	23268591.....	_____
7	2" Vacuum Hose.....	23120011.....	_____
4	1-1/2" Pipe to 2" Hose Adapter	23124011.....	_____
2	1-1/2" Street ELL	23131011.....	_____
10	#8 x 1/2" Self Drilling SMS w/Washer	93101623.....	_____
4	3/8-16 x 3" Eye Bolt.....	01008512.....	_____
1	TS Customer Skin Top	23024011.....	_____

Tubing & Suction Fitting Kit Options

<u>Description</u>	<u>Part Number</u>	<u>Checked</u>
<u>Kits for PVC Tubing</u>		
APS PVC Tubing Kit	23237991.....	_____
APS PVC Suction Fitting Kit	23273993.....	_____
<u>Kits for Steel Tubing</u>		
APS Steel Tubing Kit	23237992.....	_____
APS Steel Suction Fitting Kit	23273994.....	_____

Tubing Kits include: (1) 10' Straight Tube, (2) 90 Deg. Bends, (2) Connector Sleeves, Grounding Harness, & (2) Suction Fittings.

Suction Fitting Kits include: (2) TS Suction Fitting, & Grounding Harness, (No tubing, bends or connectors).

Additional Parts & Options

<u>Description</u>	<u>Part Number</u>	<u>Quantity</u>
<u>PVC Parts</u>		
Straight Tubing – 10’ (always requires 23117021)	23115021.....	_____
Straight Tubing w/Coupling – 10”	23115020.....	_____
Straight Tubing – 12’ (always requires 23117021)	23115022.....	_____
Straight Tubing w/Coupling – 12’	23115023.....	_____
PVC Connector Sleeve	23117021.....	_____
90 Deg. Bend – 20” CLR.....	23116021.....	_____
90 Deg. Bend w/Coupling – 20” CLR.....	23116026.....	_____
45 Deg. Bend – 20” CLR.....	23116024.....	_____
45 Deg. Bend w/Coupling – 20” CLR.....	23116025.....	_____
30 Deg. Bend – 20” CLR.....	23116031.....	_____
30 Deg. Bend w/Coupling – 20” CLR.....	23116030.....	_____
15 Deg. Bend – 20” CLR.....	23116022.....	_____
15 Deg. Bend w/Coupling – 20” CLR.....	23116023.....	_____
<u>Steel Parts</u>		
Straight Tubing – 10’ (always requires clamp or coupling sleeve)	23115011.....	_____
Straight Tube, Expanded – 10’	23115013.....	_____
Straight Tube – 12’ 6”	23115012.....	_____
Straight Tube, Expanded – 12’ 6”	23115000.....	_____
Solid Sleeve 4-1/2” ID.....	23117011.....	_____
Coupling 4-1/2” - 3 Bolt w/Neoprene Liner.....	23117030.....	_____
Clamp Sleeve 4-1/2”.....	23117031.....	_____
Shrink Sleeve 4-1/2” OD 4.5” Long.....	23118011.....	_____
Protection Sleeve 18” long	23118021.....	_____
90 Deg. Bend – 20” CLR.....	23116021.....	_____
90 Deg Bend, Expanded – 20” CLR.....	23116016.....	_____
90 Deg. Bend – 24” CLR.....	23116012.....	_____
90 Deg. Bend, Expanded – 24” CLR.....	23116017.....	_____
90 Deg. Bend – 30” CLR.....	23116013.....	_____
90 Deg. Bend, Expanded – 30” CLR.....	23116018.....	_____
90 Deg. Bend – 48” CLR.....	23116014.....	_____
90 Deg. Bend, Expanded – 48” CLR.....	23116019.....	_____
90 Deg. Bend – 60” CLR.....	23116015.....	_____
90 Deg. Bend, Expanded – 60” CLR.....	23116010.....	_____
45 Deg. Bend, Expanded	23116027.....	_____
30 Deg. Bend, Expanded	23116028.....	_____
15 Deg. Bend	23116029.....	_____

Additional Parts & Options, (cont.)

<u>Description</u>	<u>Part Number</u>	<u>Quantity</u>
<u>Carriers</u>		
Standard Pneumatic Carrier 4-1/2" (each).....	23111011.....	_____
<u>Other Parts</u>		
APS Additional Blower Pack (each)	23002993.....	_____
APS Remote Photo Eye Kit.....	23314991.....	_____
Adapter 4.5 Metal to PVC	23119011.....	_____
Firestop – 4 gal Bucket.....	23277011.....	_____
Firestop Caulk Tube	23277021.....	_____
PVC Adhesive Kit – 1/4 pt.....	23278011.....	_____
Tube Hanger 4-1/2.....	23279011.....	_____
APS Lane Light Control	23282991.....	_____
TS Bavsonic Audio Kit.....	23255191.....	_____

APS Final Inspection List

Labels and Documentation:

1. Install **Inspection** label on customer station. Record Job # & Work Order below and on the label.

Job Number _____ Work Order Number : _____

2. Install **Hi-Pot** label on each blower. _____
3. Install UL each blower. _____
4. Install **This End Up** labels on each blower. _____
5. Install **Cut To Size** label on customer lower skin lid. _____
6. Customer board serial number: _____ Checksum number: _____
7. Teller board serial number: _____ Checksum number: _____
8. Blower Manufacturers Part number: _____

Customer Unit:

1. Ensure board settings are correct. _____
2. Check door operation: open closed and ported. _____
3. Check operation of power, send, and call switch. _____
4. Check for proper belt tension. _____
5. Ensure door motor brake has been replaced. _____
6. Ensure board cover has been installed. _____
7. Check function of customer audio _____
8. Ensure safety switch is working properly. _____

Teller Unit:

1. Ensure door motor brake has been replaced. _____
2. Ensure teller skin brace has been installed. _____
3. Check operation of power, send and recall switch. _____
4. Check operation of open, close, and ported switch. _____
5. Test operation of safety switch. _____
6. Test operation of transmitter and receiver on carrier present sensor. _____
7. Install 4 ½" x 6' PVC Pipe. _____
8. Install 2 hose clamps. _____
9. Verify proper control board settings for shipping. _____
10. Verify teller door is closed for shipping _____

Blowers:

1. Install junction box cover. _____
2. Hi-Pot assembled complete unit. _____

