BavSonic™ Universal Telephone Audio

Installation and Service Manual

E. F. Bavis & Associates, Inc.

201 Grandin Road
Maineville, Ohio 45039
(513) 677-0500

BavSonic™ Universal Telephone Audio

Table of Contents

Safety Instructions	1
Features	2
Intercom Connections	3
Universal Interface Installation Instructions	3
Panasonic KX-TG4000B Installation Instructions	3, 4
KSU Telephone System Wiring Diagram.....	5
Panasonic KX-TG4000B Wiring Diagram.....	6
Intercom Wiring Diagram.....	7
Troubleshooting	8
Installation and Service Tool List for Audio	9

Important Safety Instructions

1. READ THESE INSTRUCTIONS
2. KEEP THESE INSTRUCTIONS
3. HEED ALL WARNINGS
4. FOLLOW ALL INSTRUCTIONS
5. DO NOT USE THIS APPARATUS NEAR WATER
6. CLEAN ONLY WITH A DRY CLOTH
7. DO NOT BLOCK ANY VENTILATION OPENINGS. INSTALL IN ACCORDANCE WITH THE MANUFACTURER'S INSTRUCTIONS
8. DO NOT INSTALL NEAR ANY HEAT SOURCES SUCH AS RADIATORS, HEAT REGISTERS, STOVES OR OTHER APPARATUS (INCLUDING AMPLIFIERS) THAT PRODUCE HEAT
9. PROTECT THE POWER CORD FROM BEING WALKED ON OR PINCHED PARTICULARLY AT PLUGS, CONVENIENCE RECEPTACLES AND THE POINT WHERE THEY EXIT THE APPARATUS
10. ONLY USE ATTACHMENTS/ ACCESSORIES SPECIFIED BY THE MANUFACTURER
11. REFER ALL SERVICING TO QUALIFIED SERVICE PERSONNEL. SERVICING IS REQUIRED WHEN THE APPARATUS HAS BEEN DAMAGED IN ANY WAY, SUCH AS POWER-SUPPLY CORD OR PLUG IS DAMAGED, LIQUID HAS BEEN SPILLED OR OBJECTS FALLEN INTO THE APPARATUS, THE APPARATUS HAS BEEN EXPOSED TO RAIN OR MOISTURE, DOES NOT OPERATE NORMALLY OR HAS BEEN DROPPED.

Additional Safety Instructions

WARNING – TO REDUCE THE RISK OF FIRE OR ELECTRONIC SHOCK, DO NOT EXPOSE THIS APPARATUS TO RAIN OR MOISTURE.

BavSonic™ Universal Telephone Audio Features

The BavSonic™ Universal telephone intercom interface module connects the intercom system of the two outside remote drive-thru lanes to the telephone system. This is a full duplex audio system for maximum intelligibility. The incoming audio levels are adjustable at each telephone station.

The customers at the remote-drive-thru locations can call the inside by depressing the CALL BUTTON on either lane. This initiates a call to the telephones in the building that are programmed to receive them. The employees can access each remote lane from the telephones that are given access. If a customer presses the call button and the call is not answered in approximately one minute the call is terminated for 10 seconds then another attempt is made. This will happen five times at which point the interface will reset itself awaiting the next activation of the call button.

Telephone Interface

Power is supplied to the interface through a 110v power cord and is protected by a 1 amp breaker. The customer will supply the connections from the telephone system to an area under the counter adjacent to the drive-thru window.

Telephone system requires a standard loop start CO line for each lane.

Note: The Universal TA System is not compatible with the Samsung DCS Compact phone system. If you are using this system, please contact the factory at 1-800-937-3322.

Intercom Connections

There are intercom boards located in both the window lane and remote lane. These boards are connected to the telephone interface via standard CAT 5 wiring. The termination is a type 568B. The red and blue connectors are RJ45. Red cabling designates lane one. Blue cabling designates lane two. Each intercom board has a LED, which indicates that it is receiving power.

The outgoing audio levels are adjusted at the intercom audio board. The intercom audio board for the window is attached to the black laminated filler panel under the transaction drawer. The intercom audio board for the TransTrax is located on the customer speaker panel, inside a weatherproof enclosure, of the customer unit located on the outside island. After adjustments are made, be careful not to pinch any wires during reassembly of the weatherproof enclosure.

Plug J1 is for the speaker connection. The connector is a 3-position with positions 1 & 3 being the speaker. For the outside board, plug J2 is an 8-position Microfit, for the inside board, plug J2 is an 8-position RJ-45. Plug J3 is for the call button connections. The connector is a 4-position with positions 2 & 3 being the button. Note that positions 1 & 4 are 19vdc power with position 4 being positive. Plug J4 is for the microphone connection. This connector is a 2-position.

Please see page 7 for an overall wiring diagram of the intercom section.

Installation with KSU type Telephone System

The Universal Telephone Audio Interface can be used in conjunction with most KSU type telephone systems. The following information is generic for most systems. If additional information is needed please consult the factory.

The telephone connections on the Universal Telephone Audio Interface are standard RJ11 jacks. There are two two-wire telephone cords that are provided with the interface that should be used to connect the Universal Telephone Audio Interface to the RJ45 connection of the telephone system. One cord is for the WINDOW lane the other for the REMOTE lane.

Please see page 5 for a wiring diagram of the connection to the telephone system. The CO port should be programmed for loop start. If there is a programmable delay between off hook and connection of the audio path it should be adjusted to the minimum.

Panasonic KX-TG4000B Installation

The Universal Telephone Audio Interface can be used in conjunction with any multi-line telephone. The following information is specific to a four line Panasonic system, other systems will be similar. If additional information is needed please consult the factory.

The telephone connections on the Universal Telephone Audio Interface are standard RJ11 jacks. The single four wire telephone cord that is provided with the Panasonic base unit should be used to connect the Universal Telephone Audio Interface to the telephone base unit. Please refer to the drawing on page 6.

Note that both WINDOW and REMOTE lines are available on both jacks of the Universal Telephone Audio Interface. When the cable is inserted into the WINDOW jack, the WINDOW is line 1 and the REMOTE is line 2. When the cable is inserted into the REMOTE jack, the REMOTE is line 1 and the WINDOW is line 2.

Four lane installations require two Universal Telephone Audio Interfaces. One interface is connected to the line 1/2 input and the other interface is connected to the line 3/4 input of the base unit.

TYPICAL OF CONNECTION T568A OR B

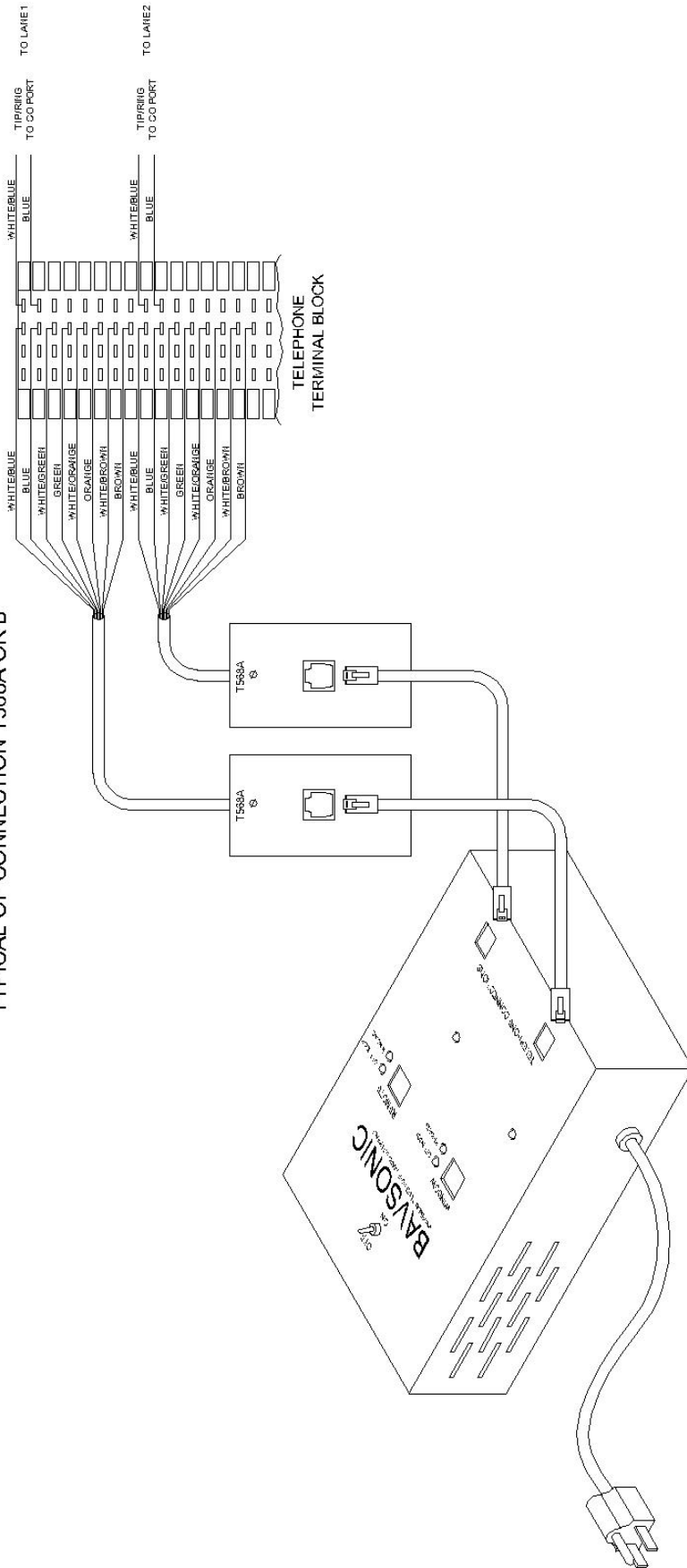

PANASONIC KX-TG4000B CONNECTIONS

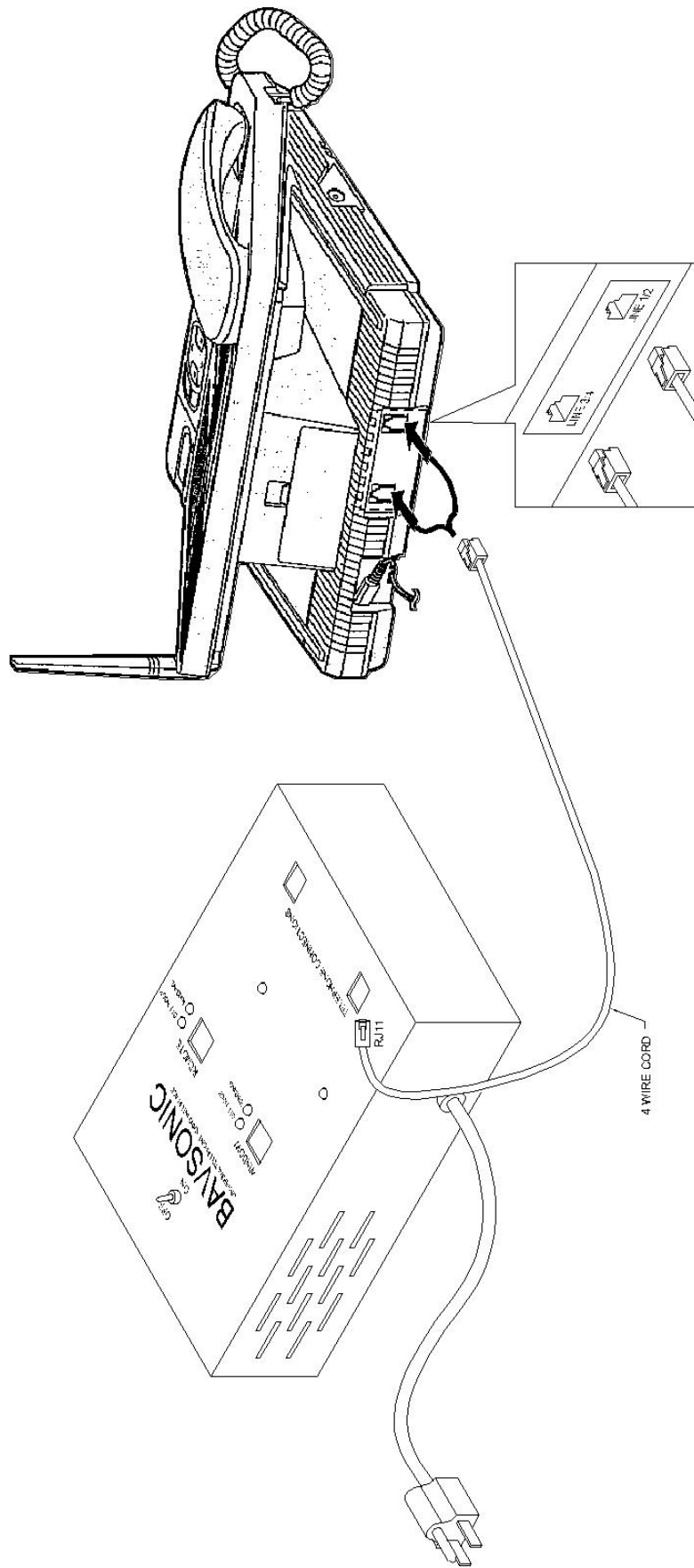

BAVSONIC INTERCOM CONNECTIONS

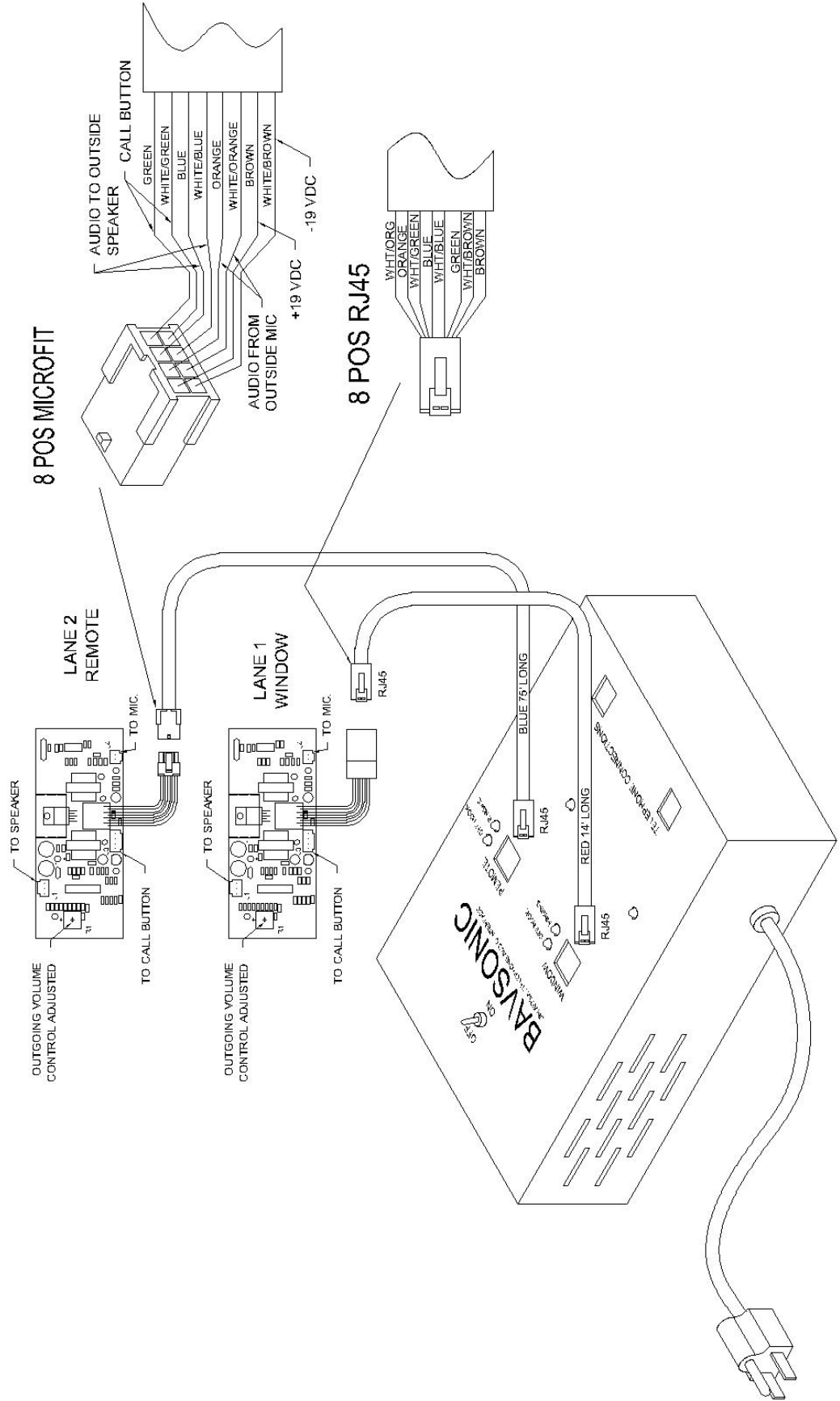

Troubleshooting

The ComCo Universal Telephone Audio Interface uses a Subscriber Line Interface Circuit (SLIC) to provide a Central Office (CO) line output. The CO line output is a standard two-wire tip ring connection with loop start. This CO line output can be connected to a telecom test set, standard telephone or Key Service Unit (KSU) for testing.

There are three states that CO line output can be in. Note that these are voltages that would normally appear on digital multi-meter, Values will differ if measured on an oscilloscope.

- 1) With or without the CO line connected and the receiver on hook the supervisory voltage should be approximately 26Vdc. Note that a flashing RED LED indicates that the system is running.
- 2) With the CO line connected and the receiver off hook the voltage should be approximately 6.5Vdc. Note that a separate YELLOW LED labeled OFF HOOK is provided for each channel to monitor this condition.
- 3) With the CO line connected, the receiver on hook or without the CO line connected and the YELLOW LED labeled RINGING illuminated the voltage should be approximately 55Vac at 20 Hz.
- 4) Without a CO connected and shorting pins 2 & 3 together will cause the OFF HOOK LED to illuminate. Note that if the intercom is connected the audio will most likely squeal due to feedback.

If any of these voltages are not present please consult the factory for assistance.

Installation and service tool list for audio

1/8" And 3/8" Flathead Screwdrivers
#0 And #2 Phillips Screwdrivers
1/16" And 3/32" Allen Wrenches
1/2" Open-End Wrench
1/4", 5/16", 11/32", 3/8", and 1/2" Nut Drivers
Wire Cutters
Wire Strippers
Wire Crimpers
Volt Meter
Electric Drill
Drill Bits
Level
7/8" Unibit
Fish Tape
Loctite