

---

# **Vittleveyor™ Revised Guide**

## **Tape Replacement Manual**

---

**P/N 00650011**

**E. F. Bavis & Associates, Inc.**

---

201 Grandin Road  
Maineville, Ohio 45039  
(513) 677-0500

# Vittleveyor™ Revised Guide Tape Replacement

## Table of Contents

Procedure .....	1
Figure 1 .....	2
Figure 2 .....	3
Figure 3 .....	4
Figure 4 .....	5
Installation and Service Tool List .....	6

## Vittleveyor™ RG Tape Replacement Procedure

1. Turn the power button on.
2. Remove all 3 pieces of the lower 3' of the tape track in the customer vertical (Figure 1).
3. Remove the old tapes and basket by jogging out to customer end (Figure 2).
4. Feed all 3 new tapes into the back slot of tape track at the customer end until tapes stop.  
Feed the tape that is 2' shorter into the center tape track.
5. While applying light and equal pressure to all 3 tapes, jog out until tapes are visible at the top of the drive surrounds. The tapes must be even, if not re-feed tapes until even.
6. Jog the tape out to the customer end.
7. With outer tapes even, cut and taper the center tape so it is 1' longer than the outer tapes.  
With a file, round and smooth the end of the tape so there are no burrs (Figure 3).
8. Mount the tape blocks with screws in the 16<sup>th</sup> and 18<sup>th</sup> holes from end of the tapes (Figure 3). The tape block on the center tape should be 12" lower than the outer tape blocks.  
(Note: The tape blocks need to be installed properly or the basket will bind and not run correctly.)
9. Insert the basket mounts into the tape blocks making sure that the lower mount is near the center of its' slot (Figure 4).
10. Jog the basket above the customer opening and reinstall the tape tracks.
11. Jog the basket past the server stop switch to reset the position logic, and check that the lower mount is still near center of the slot.
12. Push the power button off and back on to reset any flashing lights, then run the basket to check operation.

### **Service Notes:**

1. Never use an old tape with a new tape.
2. Never use any form of lubrication on the tapes.
3. Inspect the tape blocks for any damage before attaching the new tapes.

**Figure 1**

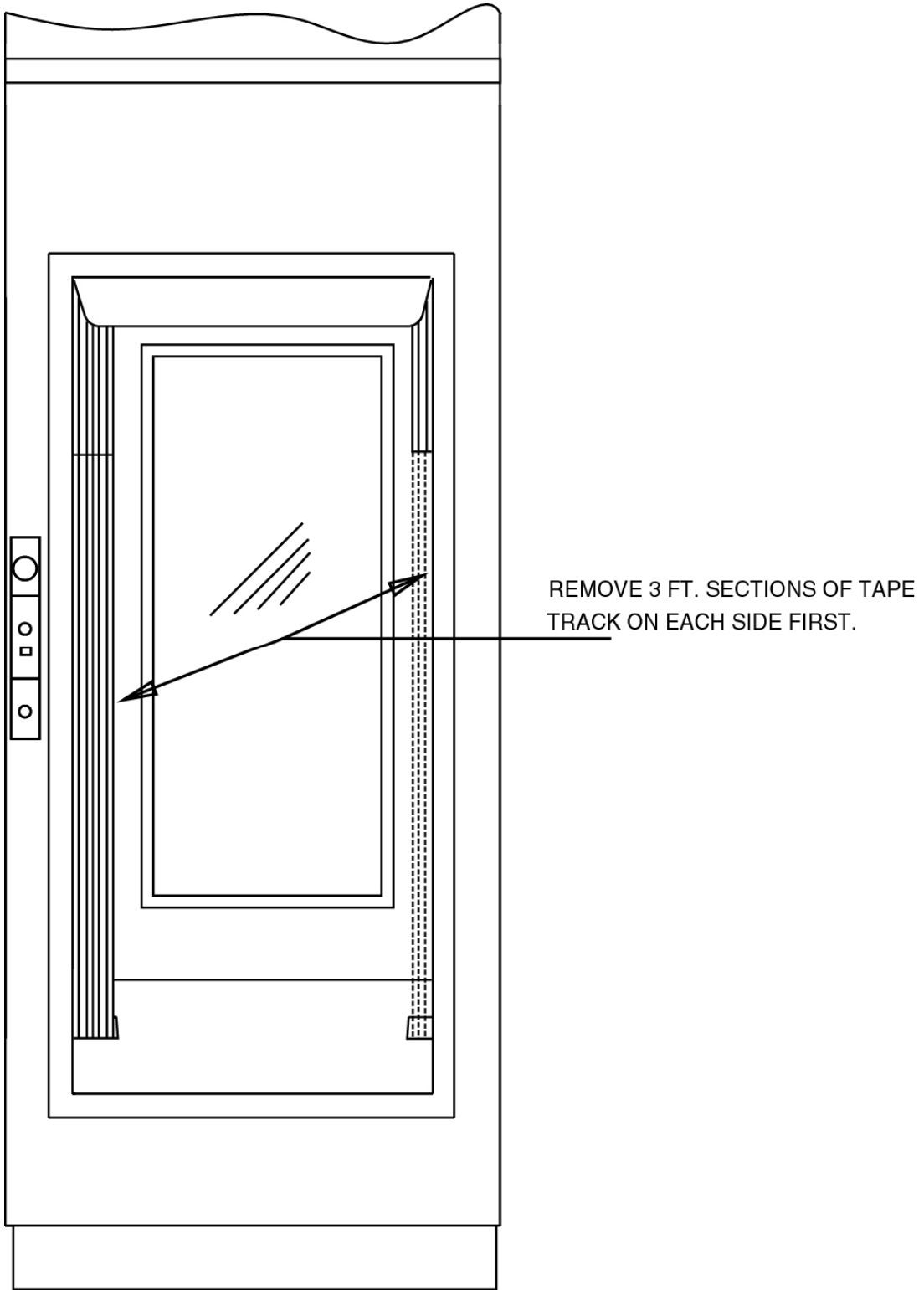
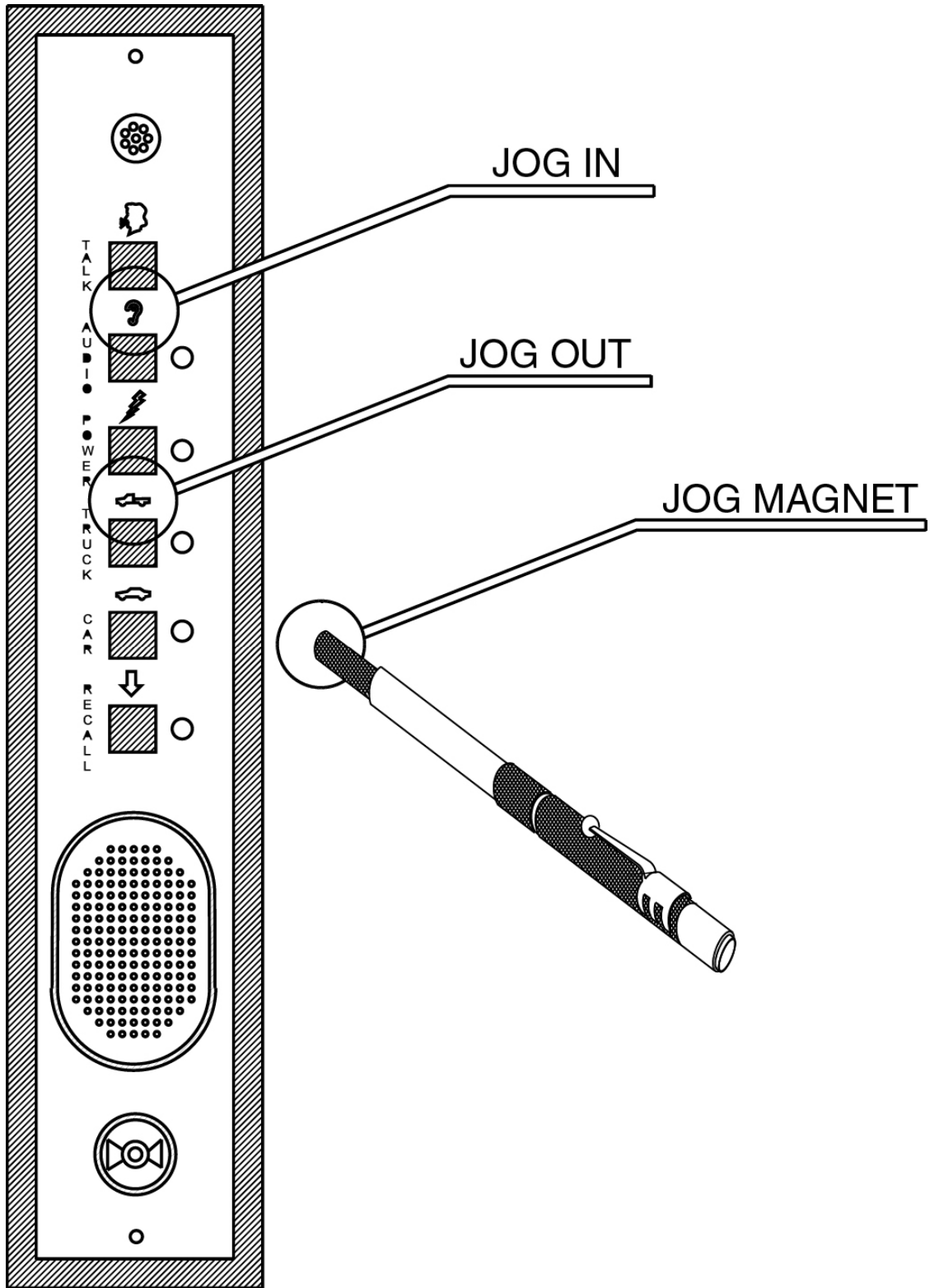

Figure 2



**Figure 3**

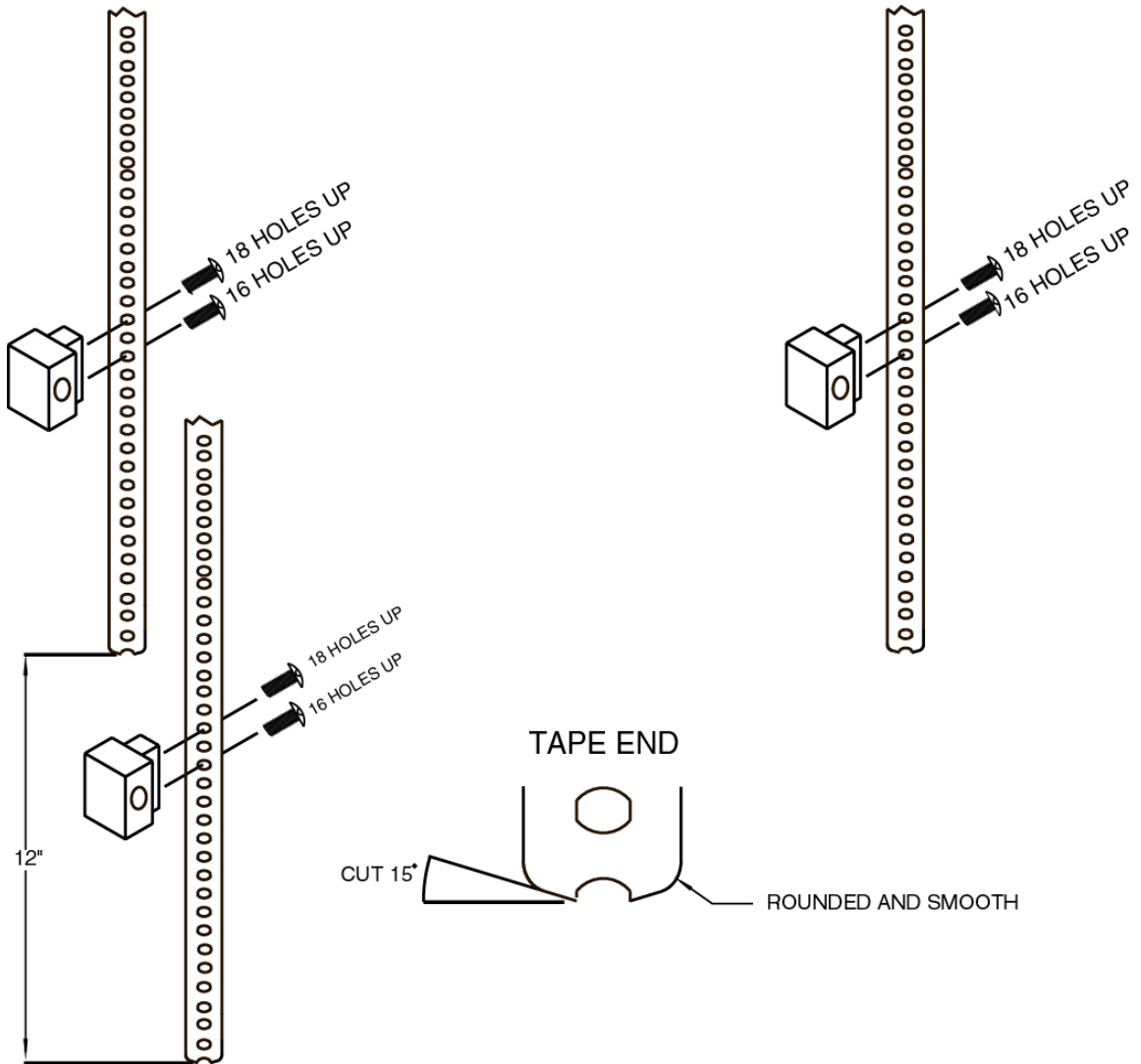
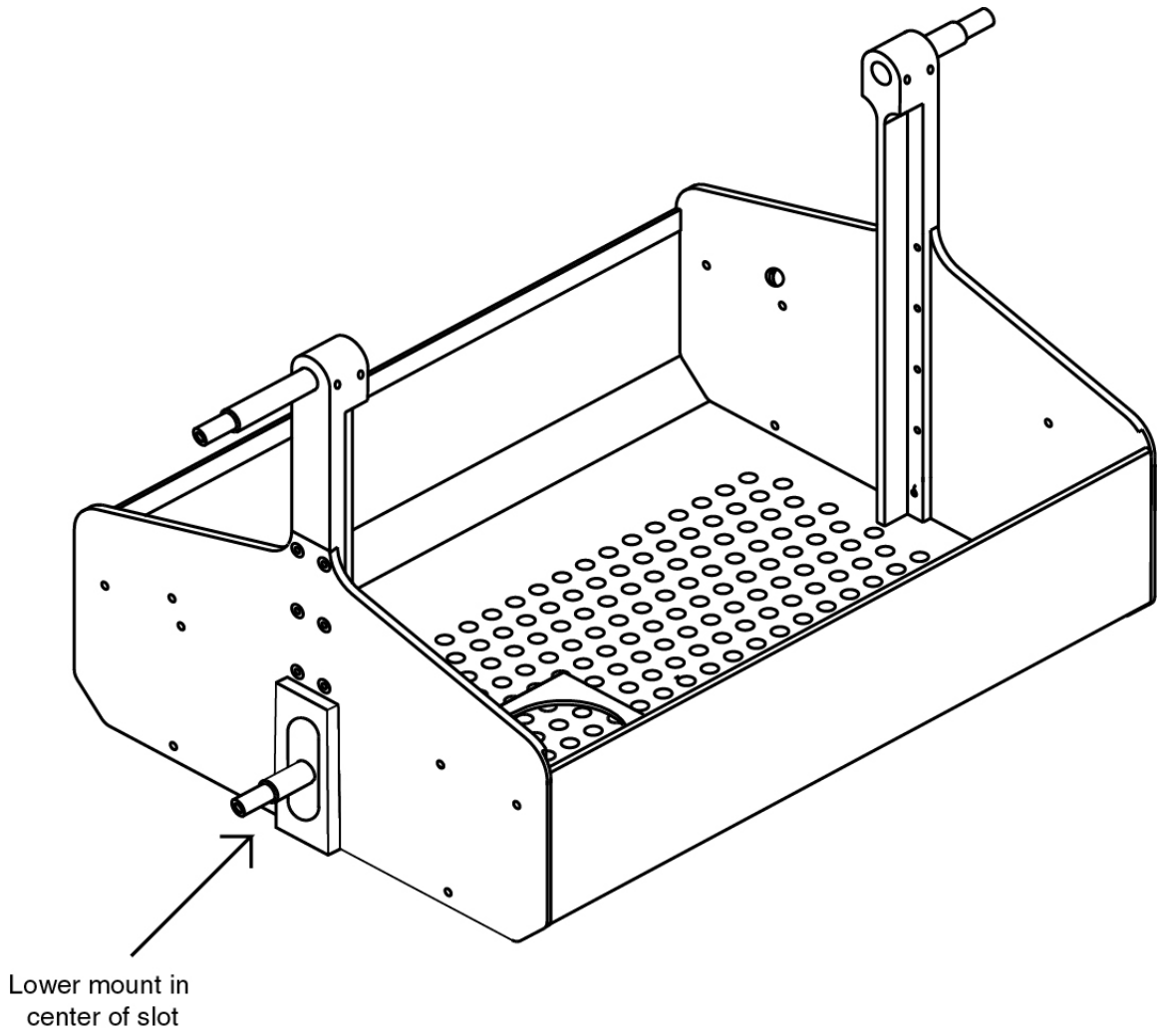

Figure 4



## **Installation and Service Tool List**

#2 Phillips Screw Driver  
Jog Magnet (P/N 06931112)  
5/32 Allen Wrench  
File  
Side Cutters  
2 sets of Tape (one spare)