

---

# **Captive Carrier TransTrax<sup>®</sup>**

## **Installation and Service Manual**

---

**Utilizing Bavcom<sup>™</sup> Audio**

**E. F. Bavis & Associates, Inc.**

---

201 Grandin Road  
Maineville, Ohio 45039  
(513) 677-0500



# Captive Carrier TransTrax<sup>®</sup>

## Table of Contents

Overview .....	1
System Layout.....	3
Installation .....	4
Airlock Assembly .....	6
Ceiling Trims .....	6
Power Connection.....	7
Installing Tape .....	8
Wiring .....	8
Power Drive Adjustment .....	8
Autocycler .....	9
Track Preparation .....	10
Customer Mounting .....	11
Mounting Block Diagram .....	12
Troubleshooting the TransTrax <sup>®</sup> .....	13
Maintaining the TransTrax <sup>®</sup> .....	15
User Instructions.....	16
Bavcom 1 on 2 Audio System .....	17
Bavcom 2 on 2 Audio System .....	21
Switch Setting Diagram .....	24
Wiring Diagram.....	25
Radius Trim Diagram .....	26
Tools Necessary for Installation .....	27
TransTrax <sup>®</sup> Shipping Manifest .....	28



# Captive Carrier TransTrax®

## Overview

The TransTrax® Captive Carrier is a mechanical, positive drive conveyor system kit intended for the conveyance of pharmacy prescriptions and documents between customers and pharmacists at drive-thru pharmacy lanes. For ease of use by customers, the door of the carrier opens and shuts automatically. The closing of the door is accomplished by spring force. The opening motion is accomplished when a lever on the bottom of the carrier contacts the inside or outside stabilizers. Inside the carrier is a spring-loaded bail to keep the receipts and small bags from falling or blowing out of the carrier. Note that the carrier inverts during its travel. Whatever is inserted into the carrier flips upside down when it is delivered.

This kit features one piece extruded architectural grade aluminum tubing, which has a satin anodized finish. The tubing can be, using a power miter box with the proper blade installed, cut and spliced to suit dimensions dictated by varying site conditions. The system is sold as a complete kit ready to install at a site. The standard kit allows for a maximum tubing centerline-to-centerline distance of 23'11". Minimum distance is 3'11". Maximum overall height is 16'. Longer, shorter and/or taller sites can be accommodated. Please consult the factory for assistance and pricing.

(Note; With factory assistance, the minimum horizontal distance from center line to center line of the vertical tube is 32 inches, maximum horizontal distance from center line to center line of the vertical tube is 33 feet, 10 inches. Maximum vertical height from the top of the horizontal tube to the drive surface or finished floor, whichever is the greater, is 16 feet.)

The TransTrax® must be run in an overhead configuration. It was not designed to accommodate "Downsend" configurations. If there is a need for this type of configuration at a given site, we suggest that you consider a product from our Autoveyor™ product line. Please contact us for more details on this product line.

In order to provide the greatest speed and safety of operation, the TransTrax® operates at two different speeds. The carrier travels at slow speed when it is exposed to either the customer or pharmacist. Then it travels at a much higher speed when in the horizontal section of the track when the carrier is not exposed to people. This model features a proven system of distance monitoring to control shift points versus less sophisticated "time based" systems. In addition, the Captive Carrier system features a mechanical brake to prevent the CARRIER from coasting when the system is off.

The Captive Carrier features dual stopping heights: high for vehicles such as vans and trucks, low for cars. There are two (high and low) premium weatherproof buttons for send. The stopping height is determined by pressing the appropriate CAR or TRUCK buttons when sending the CARRIER out to the customer. The system allows one move from car to truck or vice versa; then the CARRIER must be recalled.

Customer audio components, including wiring harness, microphone, speaker and two call buttons are included with the TransTrax®. Optional countertop audio systems are available to work this system. We offer a variety of plug-in audio systems including one on One, One on Two, Two on Two and Two on Two Audio/Video systems.

The weight capacity of the system is conservatively rated at one pound. There are safeguards built into the system which prevent catastrophic failure should the carrier be overloaded.

This system is intrinsically safe in that the mechanical power levels at the moving parts (carriage and carrier) are below 40 lbs. of force when accessible by the users. The electrical power levels at all locations other than the *INSIDE VERTICAL STANDOFF* are intrinsically safe in that they are at NEC Class II levels (24VDC 100 VAC) or lower.

The TransTrax<sup>®</sup> has been reviewed by a third party for safety and suitability for the given application. Please review the label applied to the machine for details concerning this review.

Please note that the intrinsically safe power level does require that the system be smooth running without any extra drag induced by poor fitups, misalignment at joints in the tubing and other installation related problems, or it simply won't run properly.

Each part in the kit contains a PSA label with the part name and number attached to it. Please read over this manual before installation to familiarize you with the different components and where they are used in the system.

A schematic of an installed TransTrax<sup>®</sup> system identifying major components by part number follows.

If there are questions about any of the following, contact the Technical Service Department at (513) 677-0500.

Note: Shipping manifest can be found on Page 28; a listing of required tools on Page 27.

## Autocycler

The Captive Carrier<sup>®</sup> is equipped with an autocycler that can be activated to run the car in and out. This is useful to check the unit for proper operation after installation or service.

The procedure for doing this is as follows:

1. Recall the car to the inside stop.
2. Turn the power off using the breaker located on the bottom of the black standoff.
3. Press and hold the car and truck buttons on the teller control panel while turning the breaker back on.
4. When the car starts moving, release the car and truck buttons.

To turn off the autocycler, press the power button on the teller control panel and turn off the unit. To resume normal operating procedure, press the power button and turn the unit on.

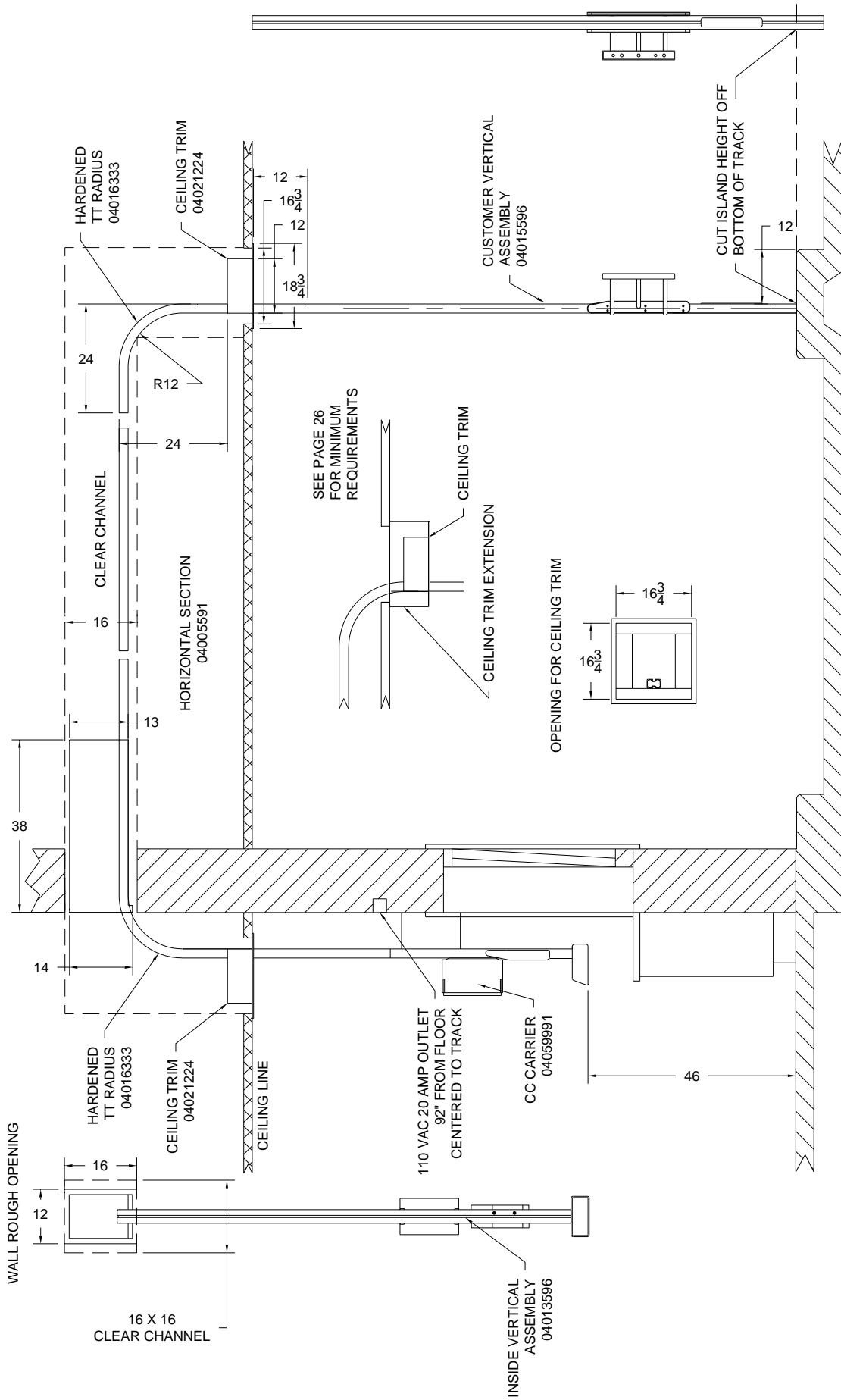

# Installation

## Installation Overview:

The process of installing a TransTrax<sup>®</sup> into a building consists of first mounting the inside vertical, attaching the radius, adding the horizontal section, attaching the customer radius, and then mounting the customer end. All wiring is connectorized and is designed to run inside the tubing.

After the tubing is installed, the *AIRLOCK ASSEMBLY* and *CEILING TRIMS* are mounted. The electrical connection is then made. The final aspect of the assembly process consists of feeding the *DRIVE TAPE* into the machine, and adjusting the electronic motor control.

The inside, customer and carrier are all tested as a unit in the factory. **Do not** mix and match components when installing a multiple lane job.

The following detailed description provides step-by-step details of this process, as well as important notes and cautions. *Read these details carefully before attempting to install the TransTrax<sup>®</sup>.*

## Installation Procedures:

The first part of the TransTrax<sup>®</sup> Kit is a completely assembled *INSIDE VERTICAL UNIT*. The system electronics are housed in the *WALL STANDOFF* portion of the *INSIDE VERTICAL UNIT*. The *WALL STANDOFF* sides open outward to expose the back. The *WALL STANDOFF BACK* needs to be mounted securely to the wall.

**CAUTION:** The *WALL STANDOFF* supports the entire weight of the *INSIDE VERTICAL UNIT*. Do not just use molly bolts or similar type mounts into the drywall. Make certain that the fasteners and mounting surface are adequate to fully support this component and the forces that occur during operation.

The bottom of the *INSIDE VERTICAL UNIT* should be positioned 46" off the inside floor. If the vision window frame obstructs the placement of the *WALL STANDOFF*, it can be repositioned up to 6" higher on the *VERTICAL TUBING* by removing its associated screws and placing it at the higher position.



### Cutting TransTrax<sup>®</sup> Tube:

The TransTrax<sup>®</sup> system uses a proprietary aluminum extrusion. This extrusion must be cut using carbide tipped circular saw blade in a power miter box. ***No other way of cutting the tube is acceptable.***

Many have tried to use an abrasive blade installed in a power miter box to cut the tube. Do not use this method as it will yield cuts that will not function properly. Further, since the cuts must be made dead square, a good quality miter box is the only acceptable way to make the cuts.

If you have any questions regarding the proper method of cutting the tubing, please contact the factory. ***Cutting the tube properly is key to making the system function properly.***

The *INSIDE VERTICAL EXTENSION* should be cut to a dimension which will allow the *FORMED RADIUS* to exit the building via the 16" x 24" clearance hole in the wall. The *INSIDE VERTICAL EXTENSION* must then be deburred and the tape slot chamfered<sup>1</sup>.

**NOTE:** The area of the *TAPE SLOT* where the tubes are joined must actually be *CHAMFERED* on both tubes and on the top and bottom track and not just deburred to allow the tape to pass easily in the event of a slight misalignment. Inspect the factory prepared ends for an example. The factory prefers to use a conical rotary cutter in a high speed grinding tool such as a Dremel.

Pass the *WIRING HARNESS* through this section and all other tubing, as the unit is assembled. Sometimes “fishing” the wiring harness through the tubing can be a challenge due to the screws, etc. We have found that a “fish tape” does a great job. Just attach one end of the harness to a 10-12’ length of tape with electrical tape and push the tape through the tube. The harness can then be easily pulled through using the tape to pull the harness. Attach the tubing to the *TELLER VERTICAL UNIT* using two of the extruded internal *SPLICE PLATES*<sup>2</sup>. Be careful when running screws into the tubing not to nick or cut any of the wires.

The *FORMED RADIUS* needs to be attached to the *INSIDE VERTICAL EXTENSION* using the extruded internal *SPLICE PLATES*<sup>3</sup>.

---

<sup>1</sup>Fig. 1

<sup>2</sup>Fig. 2

<sup>3</sup>Fig. 2

**CAUTION:** The *FORMED RADII* are not designed to be cut. They were designed to be used as is. Any modifications to this component voids the warranty and will likely yield less than acceptable operation.

The *CUSTOMER VERTICAL UNIT* is completely assembled and designed for installation at a site with no elevation difference from the lane to the island. Measure the distance from the lane to the island and cut this amount off of the bottom of the *CUSTOMER VERTICAL UNIT*. It mounts to the island with a *CUSTOMER BASE UNIT*. The *CUSTOMER BASE UNIT* mounts to the island via two 3/8" holes (Note: base unit to island fasteners not provided) and to the *CUSTOMER VERTICAL TUBING* via two self-drilling screws<sup>4</sup>. The *CUSTOMER VERTICAL UNIT* is 120" tall. It needs to be cut to length which will allow the *HORIZONTAL TUBING* to be plumb horizontally after the *FORMED RADIUS* is attached to it. Be sure to deburr and chamfer each end of the tubing<sup>5</sup> before proceeding.

**CAUTION:** When cutting off the top of the customer unit, make sure that the vertical cable from the customer unit is pulled back down the customer tube to prevent cutting the cable.

The *FORMED RADIUS* needs to be attached to the *CUSTOMER VERTICAL UNIT* using the extruded internal *SPLICE PLATES*<sup>6</sup>.

The *HORIZONTAL TUBING* needs to be cut to a dimension which will allow both of the vertical units to be plumb vertically after it is installed to the *FORMED RADII*. Be sure to deburr and chamfer each end of the tubing<sup>7</sup> before proceeding.

### **Airlock Assembly:**

The *AIRLOCK ASSEMBLY* is a two-piece design. Attach the *AIRLOCK BOTTOM* using the self drilling screws provided<sup>8</sup>. Note the alignment tabs on this part that center it on the tube. The notched end goes on the radius. Install the *AIRLOCK TOP* to the *BOTTOM*. Fill the area between the *AIRLOCK ASSEMBLY* and the 16" x 24" opening with insulating material and cover with drywall, sheathing board or other appropriate material.

### **Ceiling Trims:**

Secure the *CEILING TRIM* halves together around the TransTrax<sup>®</sup> tube with the 8-32 hardware provided. Holes must be predrilled with the short 9/64" bit provided in the installation accessories to prevent drilling into and damaging wiring. Attach the ceiling trim to the tubing of the

---

<sup>4</sup>Fig. 3

<sup>5</sup>Fig. 1

<sup>6</sup>Fig. 2

<sup>7</sup>Fig. 1

<sup>8</sup>See Drawing on Page 3

TransTrax<sup>®</sup> with the #8x1/4" self-tapping screws provided. These screws do not protrude into the tubing greatly simplifying running the wiring. Note: The trim must be on the vertical section of tubing, not the radius. If it is necessary to attach the trim to the ceiling, it will be necessary to drill holes for this purpose, as there are no holes provided for this. Test the machine to insure that there is nothing preventing the car from traveling through the flaps.

**NOTE:** *CEILING TRIMS* are designed to be mounted on the vertical tube and are not designed to be mounted on the *FORMED RADIUS*. When installing trims, make sure that the *CAR* moves freely through the trim and does not rub or bump the sides of this component.

Note that six 1" angled reinforcement plates are included in the installation accessories of each TransTrax<sup>®</sup>. These are intended to be used when installing the ceiling trims and airlocks when it is not possible to get fasteners in from the bottom of the tube or the sides. Simply attach the angle to the airlock bottom or ceiling trim back and then the side of the tube.

### **Power Connection:**

The AC Line connection is at the top of the *INSIDE VERTICAL STANDOFF*. Connection method should comply with all authorities having jurisdiction, (i.e. National, State or Local Electrical Codes). A 1/2" knockout is provided on a single gang box cover. Removing the cover will reveal three leads for termination.

*The white wire is the neutral.  
The black wire is the hot. (Single phase 120vac)  
Green is for ground.*

**NOTE:** To reduce the risk of shock hazard of both line voltage and static, the ground must be connected to a good earth ground.

The wiring can be enclosed in flexible metallic or nonmetallic conduit. If a cord connection is acceptable, one is provided in the kit complete with a romex connector. **NOTE: On the supplied cord the ribbed wire is the neutral connection and the smooth wire is the HOT.** Please reduce the cord to a minimum length before connecting. Do not use an extension cord for permanent wiring and do not run the cord through or conceal in walls, ceilings and or other permanent fixtures.

Press the **POWER BUTTON** once. The LED above it should come on indicating that the unit has power. Pressing it again should toggle the power off.

## Installing Tape:

**NOTE:** The AC power must be on to install the tape as this machine has a mechanical brake that requires power to release.

Remove the *CUSTOMER SPEAKER PANEL*. Feed the *TAPE* into the tape slot at the *CUSTOMER SPEAKER OPENING* insuring that it pushes smoothly all the way into the power unit of the *INSIDE VERTICAL UNIT*. Cut the tape two feet longer than this dimension. Remove the tape and dress the ends<sup>9</sup>. Attach the *CARRIER* to the *TAPE*<sup>10</sup>. Before reinserting the prepared tape with *CARRIER* attached, take a section of the discarded tape (two feet will do) with square cut ends and run it through the system by hand with a screwdriver. If any rough spots or obstructions exist, correct them before proceeding. Reinsert the *TAPE* into the tape slot. At the *INSIDE VERTICAL UNIT*, Press and hold the brake release while inserting the tape. Note that the *LED* comes on.

Engage the tape with a small screwdriver pushing firmly down, without damaging the tape, consistently, but slowly, allowing the tape to engage the gear, wrap around and feed into the tape return slot. Do this until the magnet block of the *CARRIER* is engaging the upper black non-contact switch on the *CUSTOMER VERTICAL UNIT*. Replace the *CUSTOMER SPEAKER PANEL*.

Carefully jog the car inside and back outside while checking that there is nothing obstructing or binding the car. Release the switch back to the normal position.

With the power on, pressing the "**RECALL**" button should cause the **CARRIER** to come in. By pressing the "**CAR**" button, the **CARRIER** should go out to the lower car stop position. By pressing the "**TRUCK**" button, the **CARRIER** should go out to the higher truck stop position. Note that the microprocessor control will only allow one move between car and truck or truck and car before it will require the car to be recalled inside. If the carrier does not run, or does not run smoothly, please consult the factory for assistance.

## Wiring:

The wiring for the TransTrax<sup>®</sup> is connectorized and is enclosed within the tubing of the machine. The vertical cable extends through the radii and connects with the horizontal cable on each end. The horizontal cable is identical on both ends and cannot be installed backwards.

## Power Drive Adjustment:

Open the hinged *INSIDE STANDOFF LEFT COVER*<sup>11</sup> to get access to the *MOTOR CONTROL BOARD*. The shift point adjustments are next. There are three adjustments, **SEND**, **RECALL** and

---

<sup>9</sup>Fig. 5

<sup>10</sup>Fig. 6

<sup>11</sup>See Drawing on Page 3 for location of Standoff and the Drawing on Page 19 for specifics on the Control Board and Wiring.

**HIGH. SEND** adjusts when the carrier shifts from low into high speed when the **CARRIER** is sent from inside to customer. **RECALL** adjusts when the **CARRIER** shifts from low into high speed when the **CARRIER** is sent from customer to inside. **HIGH** adjusts how long the **CARRIER** stays in high speed.

The **CARRIER** should be in low speed when traveling through the **AIRLOCK, RADII** and in sight of users. It should be in high speed only in the **HORIZONTAL** section. If the car is in high speed in the radii, the **CARRIER** may flip out of the car. Adjust the **SEND** pot so that when the **CARRIER** is traveling from the inside to customer, it shifts into **HIGH SPEED** after it comes out of the **AIRLOCK**. Adjust the **HIGH** pot so that the **CARRIER** shifts back into low before it enters the **CUSTOMER FORMED RADIUS**. Adjust the **RECALL** pot so that when the **CARRIER** is traveling from the customer to the inside, it shifts into **HIGH SPEED** after it comes out of the **CUSTOMER FORMED RADIUS**. Observe that the **CARRIER** shifts back into slow before it enters the **AIRLOCK**. Readjust as necessary so that the **CARRIER** is in high speed only in the **HORIZONTAL SECTION** but not in the **AIRLOCK or FORMED RADII**. Note: The shift points are controlled by a microprocessor that is monitoring the rotation of the sprocket shaft and the settings should not vary due to speed, voltage, temperature, age of machine, etc. Position 1 of dip switch DS1 controls the range of the adjustment for the high speed. On=Long, Off=Short.<sup>12</sup>

If there is a problem with a carrier missing a switch, check to see what the gap between the switch and the magnet is. Anything over 1/8" and the potential for missing switches exists. This can sometimes be adjusted by loosening the black carrier stabilizers and raising the side opposite the magnet, lowering the side with the magnet or a combination of both. Note that the carrier has to have some clearance to the stabilizers to prevent it from binding.

A run limit timer is factory preset at 45 seconds as apposed to 18 seconds previously. On all Microprocessor Boards dated 1/19/00 or after, the Run LED is on constant. The only time the Run LED goes out is if the **CARRIER** times out. If the Run LED is off, the run time limit has been exceeded. Toggling the On/Off button will reset the timer. If the **CARRIER** is obstructed during its travel, the motor will shut down after this delay. If more or less time is needed, please consult the factory for assistance.

Close and secure *INSIDE STANDOFF LEFT COVER*.

## Autocyler

The Captive Carrier<sup>®</sup> is equipped with an autocyler that can be activated to run the car in and out. This is useful to check the unit for proper operation after installation or service.

The procedure for doing this is as follows:

5. Recall the car to the inside stop.
6. Turn the power off using the breaker located on the bottom of the black standoff.
7. Press and hold the car and truck buttons on the teller control panel while turning the breaker back on.
8. When the car starts moving, release the car and truck buttons.

To turn off the autocyler, press the power button on the teller control panel and turn off the unit. To resume normal operating procedure, press the power button and turn the unit on.

---

<sup>12</sup>See Drawing on Page 17 for Dip Switch Settings

# TRACK PREPARATION

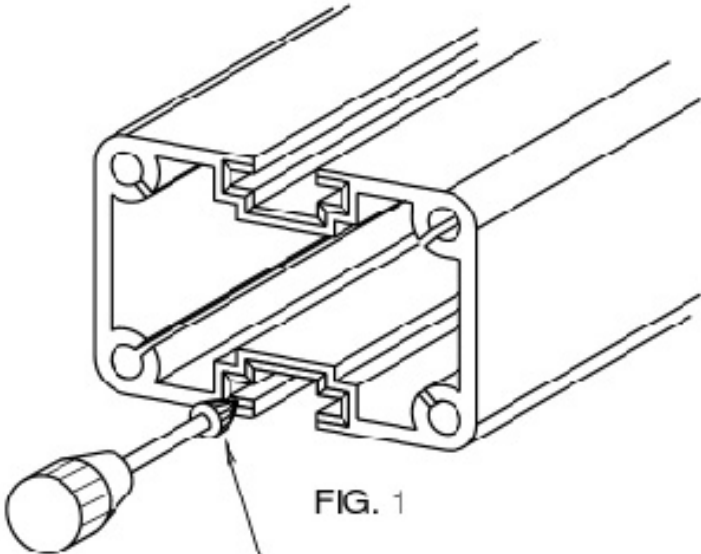

USE 1/8" CONICAL BURR  
# 125 DREMEL

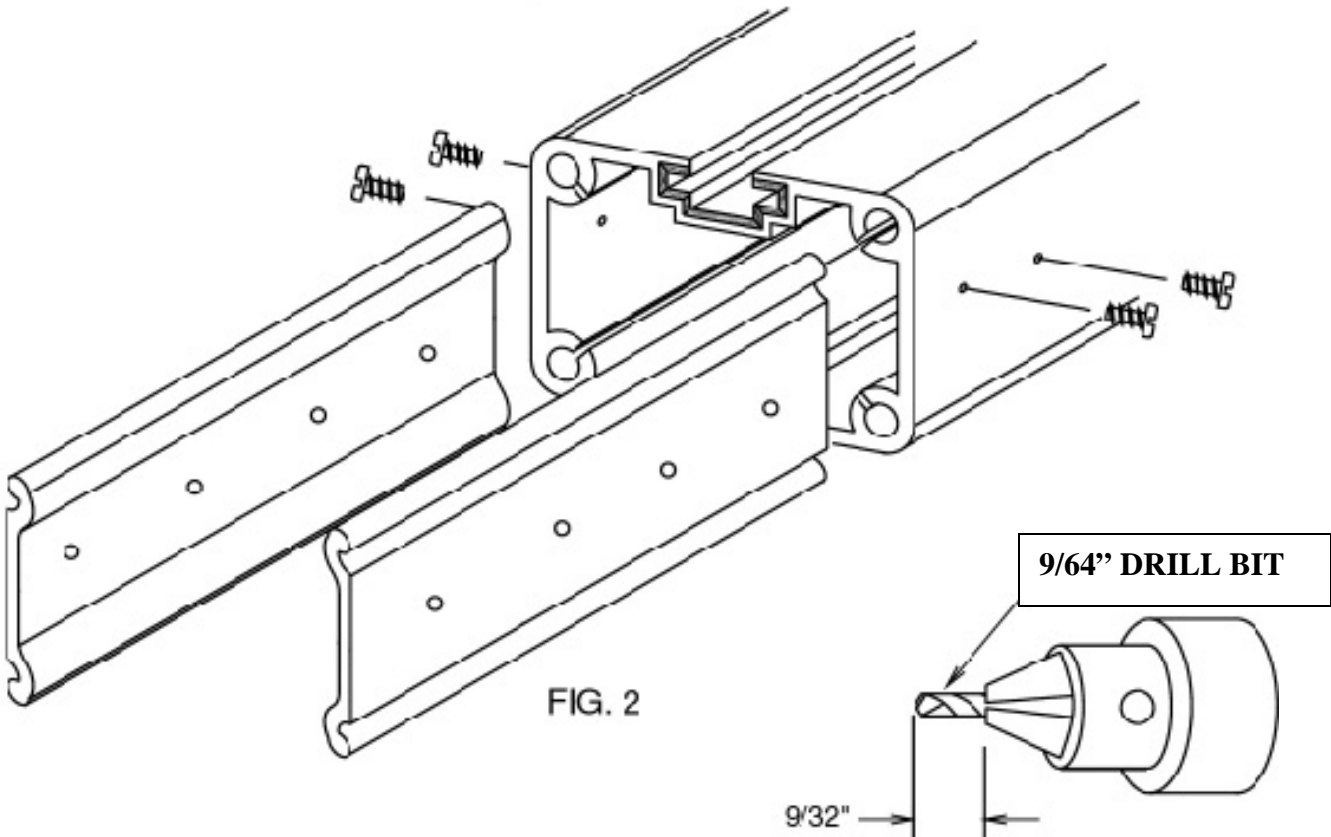
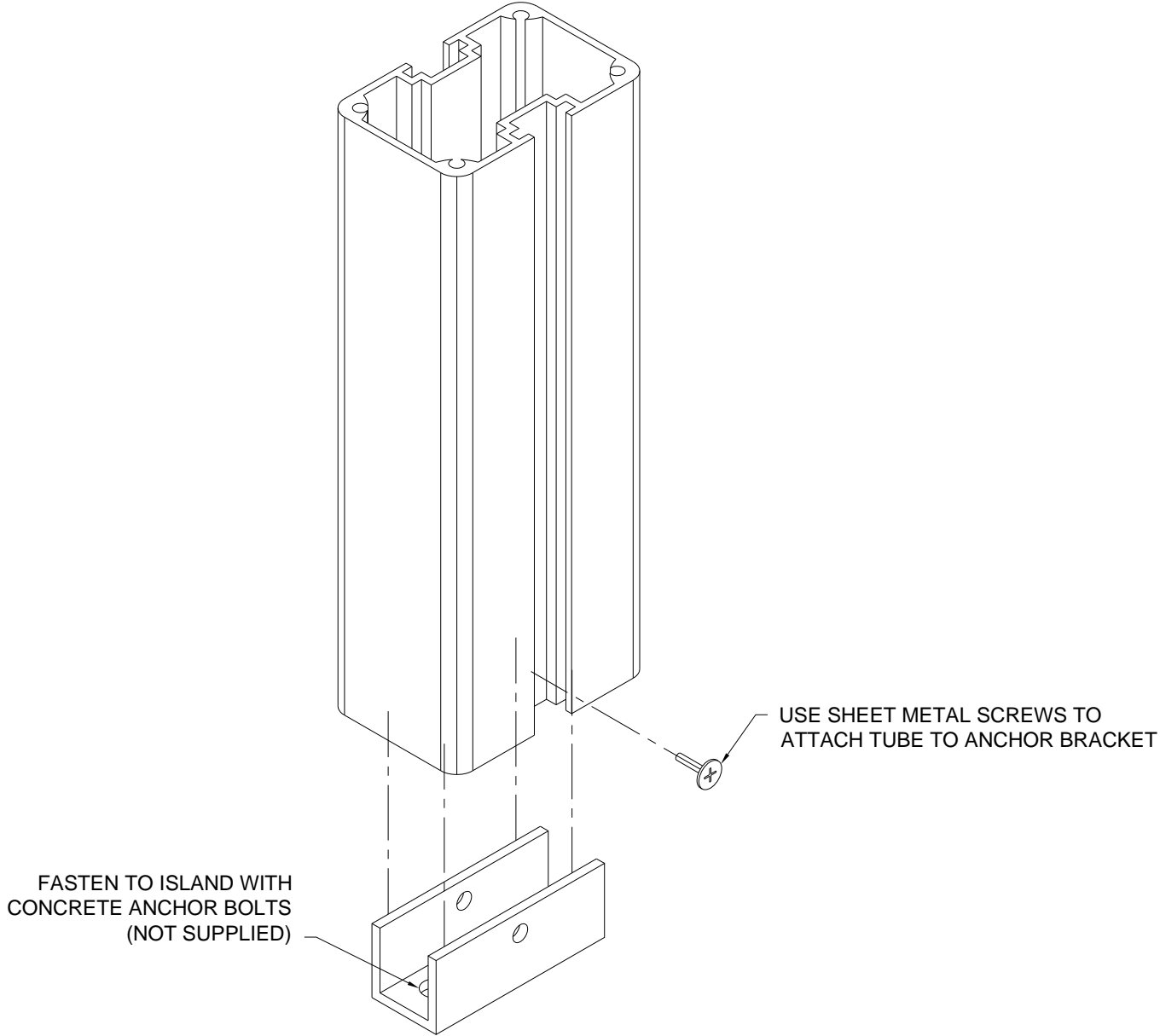

FIG. 2

9/64" DRILL BIT

9/32"

# Customer Mounting



## TAPE PREPARATION

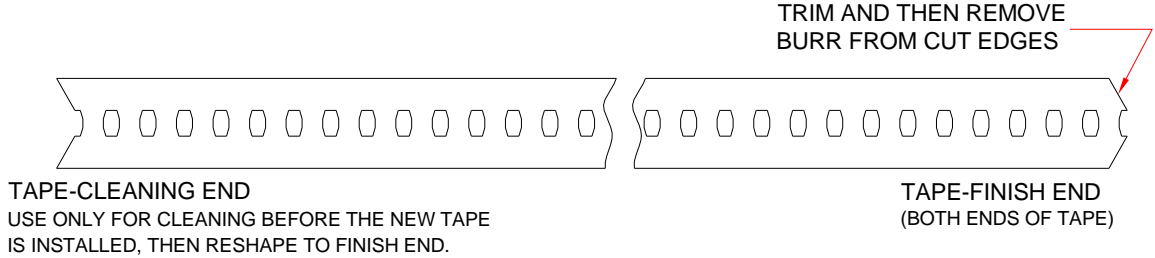

# Tape Block Mounting Diagram

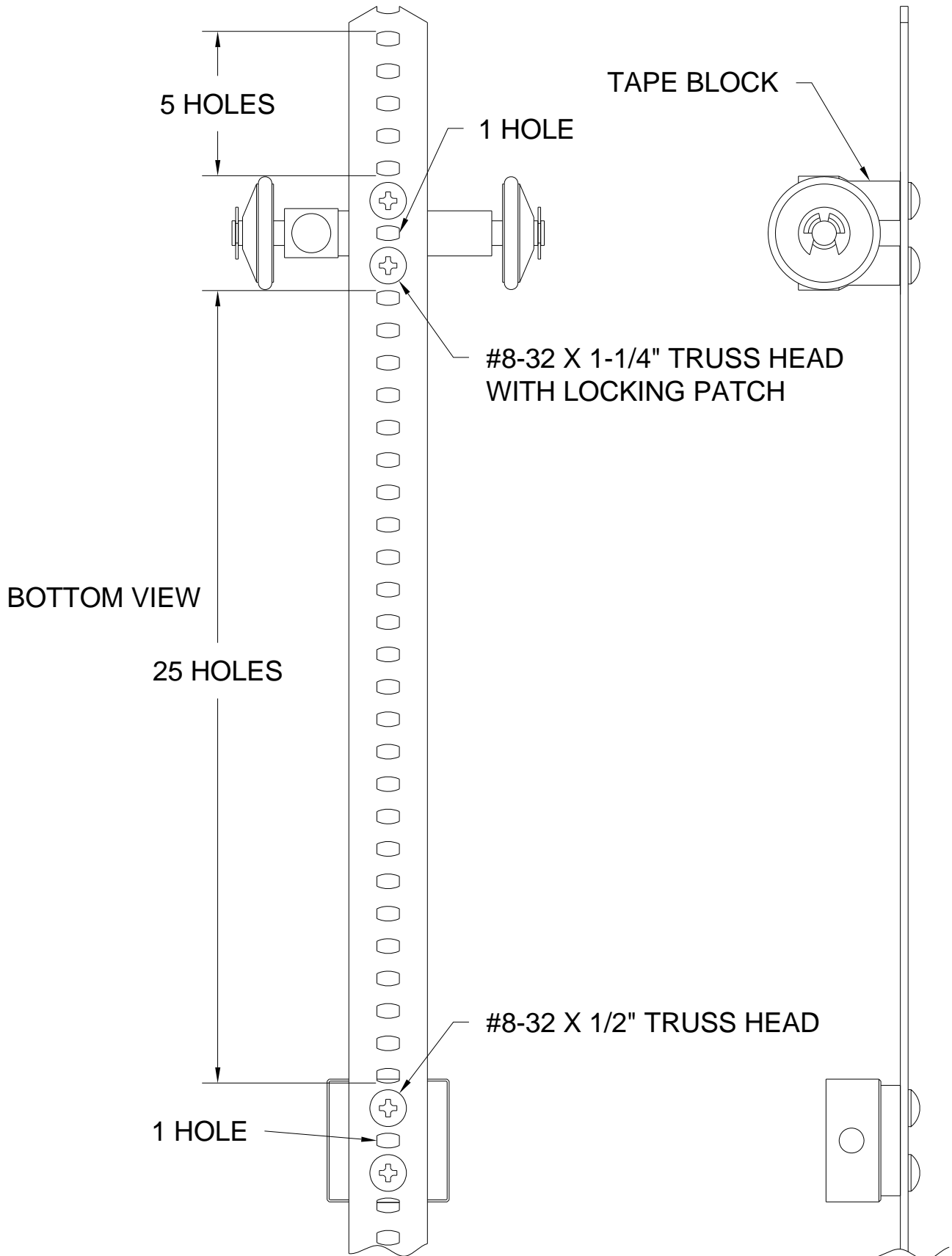



## Troubleshooting the TransTrax®

This section assumes that the machine in question has been inspected for loose, damaged or missing parts, tape, belts, wiring, etc.

### **NOTHING WORKS:**

Check the circuit breaker on the bottom of the Teller Unit Standoff. Reset it by toggling it off and back on. Nothing still works, check to insure that there is 110 VAC power coming into the machine. If there is no AC Power, have an electrician restore power to the machine. If there is power, check the fuse marked F1. If it is blown replace it with a 10A fast blow fuse. If the fuse blows again, replace the control board. If nothing still works, please consult the factory.

### **POWER ON LED WON'T COME ON OR GO OFF:**

Check the *LED* marked *PWR* while pressing the **POWER SWITCH**. The *PWR LED* should only be on while the switch is depressed. If the *PWR LED* is on all the time, replace the *INSIDE SWITCH ASSEMBLY*. If the *PWR LED* does not come on, check the switch on the brake control board to insure that it is in the normal position. If the *PWR LED* still will not come on replace the *INSIDE SWITCH ASSEMBLY*. If the *PWR LED* still does not come on replace the control board.

### **CARRIER WON'T RUN IN WHEN RECALL BUTTON IS DEPRESSED:**

This presumes that the carrier will run out. Check the *LED* marked T-L, inside limit. It should not be on. If it is, replace the *INSIDE STOP SWITCH*. If it is not, press the button marked recall. When the recall button is depressed, the *LED* marked RCL, recall, should be on. If it does not come on, replace the *INSIDE SWITCH ASSEMBLY*. If it does come on, replace the *CONTROL BOARD*.

### **CARRIER WON'T RUN IN WHEN CUSTOMER START BUTTON IS DEPRESSED:**

This presumes that the carrier will run out. Check the *LED* marked T-L, inside limit. It should not be on. If it is, replace the *INSIDE STOP SWITCH*. If it is not, press the customer start button. When the button is depressed, the *LED* marked RCL, recall, should be on. If it does not come on, replace the *CUSTOMER START SWITCH*. If it does come on, replace the *CONTROL BOARD*.

### **CARRIER WON'T RUN OUT WHEN THE CAR BUTTON IS DEPRESSED:**

This presumes that the carrier will run in. Check the *LED* marked C-L, customer limit. It should not be on. If it is, replace the *CAR STOP SWITCH*. If it is not, press the inside button marked **CAR**. When the button is depressed, the *LED* marked *SND*, send, should be on. If it does not come on, replace the *INSIDE SWITCH ASSEMBLY*. If it does come on, replace the *CONTROL BOARD*.

### **CARRIER WON'T RUN OUT WHEN THE TRUCK BUTTON IS DEPRESSED:**

This presumes that the carrier will run in. Check the *LED* marked *TR-L*, truck limit. It should not be on. If it is, replace the *TRUCK STOP SWITCH*. If it is not, press the inside button marked **TRUCK**. When the button is depressed, the *LED* marked *TRK*, truck send, should be on. If it does not come on, replace the *INSIDE SWITCH ASSEMBLY*. If it does come on, replace the *CONTROL BOARD*.

**CARRIER WON'T RUN EITHER DIRECTION:**

This presumes that the power *LED* works properly. If it does not, go to the paragraph on "*NOTHING WORKS*". First replace the *MOTOR FUSE*. Replace it only with an AGC10 fuse. This is a U.L. listed fuse rated for 120vac. Do not use fuses rated for only 32vac. If the carrier does not run, proceed to the paragraph "*CARRIER WON'T RUN IN WHEN INSIDE RECALL BUTTON IS DEPRESSED*". If the carrier still won't run, replace the *MOTOR*.

**CARRIER WON'T SHIFT INTO HIGH SPEED:**

Adjust the speed shift points as instructed on page 9. If the carrier will still not run in high speed, monitor the voltage to the motor at the connections to the motor in the power module. Note: These connections are fully insulated quick connects; however, there is room to carefully slip meter leads into them sufficient to make contact for measuring purposes. The motor must be connected for this test. Run the carrier. The voltage should be approximately 36vdc in slow and 88vdc in high. If the voltage changes and the speed doesn't, inspect the machine for anything causing excessive drag such as damaged tape, bows, sags or misalignment in the track or bad bearings in the surround. If the voltage doesn't change, observe the *CHAIN LED*. This *LED* should flash on twice for each revolution of the motor. If it does not, check SJ1 connection on the control board. If connection is o.k., replace the **DRIVE ASSEMBLY**. If it still does not, replace the *CONTROL BOARD*.

**CARRIER IS IN HIGH SPEED IN THE VERTICAL SECTIONS:**

Adjust the speed shift points as instructed on page 9.

**CARRIER OVERRUNS STOP POSITION ON INSIDE END:**

First, insure that the carrier is traveling in the slow speed in the vertical section. Check to insure that the gap between the magnet and the black switch is 1/8" or less. With the carrier at the stop position and the magnet positioned on one of the stop switches, check the *LED* labeled T-L. It should be on. If it is not, replace the *SWITCH*; if it is still not on, replace the *CONTROL BOARD*.

**CARRIER OVERRUNS THE CAR & TRUCK STOP POSITIONS ON THE CUSTOMER END:**

First, insure that the carrier is traveling in the slow speed in the vertical section. Check to insure that the gap between the magnet and the black switch is 1/8" or less. With the carrier at the stop position and the magnet positioned on one of the stop switches, check the *LED* labeled C-L. It should be on. If it is not, replace the *SWITCH*; if it is still not on, replace the *CONTROL BOARD*.

**RELAYS AND BRAKE CLICK; MOTOR WON'T RUN:**

There is a brake interlock switch, which prevents the motor from running unless the brake fully releases. Check J11 connection on the Control Board. If you still experience this problem, please consult the factory.

# Maintaining the TransTrax<sup>®</sup>

## **Overview:**

The TransTrax<sup>®</sup> was designed to require very little maintenance; however, what is required is critical in order for the unit to operate as trouble free as possible.

## **Weekly Maintenance:**

Weekly, or even daily, the TransTrax<sup>®</sup> should be wiped down on both the customer and inside end to remove road grime and other environmental contaminants.

**NOTE:** Cleaning is the single most important aspect of TransTrax<sup>®</sup> maintenance.

One may also notice a light gray to black dust. This material is produced by the TransTrax<sup>®</sup> in its process of self-lubrication. It is normal for this dust to form. However, it should be removed in the cleaning process.

**CAUTION:** The TransTrax<sup>®</sup> does not require any form of lubrication as part of any maintenance. Do not put oil, grease, WD-40 or any other form of lubrication on any component of the TransTrax<sup>®</sup>. Doing so voids all warranties on the product.

## **Annual Maintenance:**

Annually, we recommend replacement of the drive tape and inspection of the drive sprocket and drive surround. At that time we also recommend a complete cleaning of the track system with the tape removed.

Under plant conditions, the drive tape lasts between 60,000 and 100,000 cycles<sup>13</sup> in the TransTrax<sup>®</sup>. However, conditions of the "real world" may be harsher than the environment found in our plant. Given the relative low cost of tape replacement on a scheduled basis compared to the cost of unpredictable down time and loss of customer service, we recommend the tape be replaced annually.

If the tape is run until the point of failure, there is a danger that either the drive sprocket or the drive surround will be damaged.

---

<sup>13</sup> A single cycle is a complete out and back transaction.

### **Other Components:**

The motor is designed to provide in excess of 600,000 cycles under plant conditions. Actual life under "real world" conditions will vary. Since the TransTrax<sup>®</sup> uses a totally enclosed non-vent DC motor, the failure after its rated life is caused by worn out brushes. While it is possible to re-brush the motor, it is not recommended, nor does the factory support it.

The other drive components are designed to outlast the motor; however, they can be damaged during a tape failure. It is, therefore, recommended that the annual tape replacement practice be followed.

## **User Instructions**

### **Carrier Movement:**

Once the power button has been pressed and the Power *LED* is illuminated, pressing the SEND button sends the carrier out to the customer end of the unit. Pressing the RECALL button brings the carrier back into the inside end of the unit.

### **Overloaded Carriers:**

If a carrier is overloaded by a customer, there are two possible outcomes when the carrier is sent in toward the inside end:

#### Carrier does not move:

If the carrier does not move when the send or recall button is pressed by either the customer or inside, remove the contents from the carrier. Send it into the inside and then return it to the customer end. The TransTrax<sup>®</sup> is now ready for use.

#### Carrier does not arrive at inside station:

If an overloaded carrier box has been sent into the pharmacy and has not arrived at the inside station, there are two options:

##### Press the button again:

Press the **RECALL** button repeatedly until the carrier arrives. If, after several attempts, this does not work, consult the factory.

##### Remove contents and retrieve:

Have a service person get to where the carrier is located. Remove the contents and then have a user press the **RECALL** button. The car should move to the inside end and upon arrival be ready for normal use.

As you can see, operation of the unit was designed to be simple.

## Bavcom 1 on 2 Audio Systems **Adjustment**

It is necessary to open the console to adjust the gain controls. Access is gained by turning the two thumbscrews on the back of the console. The fasteners are captive and will not get lost or misplaced. After the fasteners are fully unscrewed, the front portion of the case hinges forward for easy access.

Each position has separate gain controls and needs to be adjusted independently. For details on the location of the adjustments, see Figure 1. The adjustment procedure is the same for each position.

With the teller speaking in the inside microphone and a car present at the customer unit, the outgoing volume control corresponding to that position should then be adjusted for satisfactory volume. The incoming volume control corresponding to that position should then be adjusted clockwise until feedback occurs, then counterclockwise until feedback stops. This should complete the adjustment. If the incoming level is not sufficiently high enough, the outgoing level will have to be reduced to be able to get additional incoming volume level. The gain levels are a balance; adjustment of each has an effect on the other. If the incoming level is too high, adjust it to a lower level. Reassemble the console. **Note: The incoming volume knob should be all the way clockwise for this procedure.**

With a lane selected, press the **boost in** button. The incoming should get substantially louder while the outgoing is muted. Press the **boost out** button. The outgoing should get substantially louder while the incoming is muted. If feedback occurs, consult the factory.

## **Board Replacement**

When replacing the 1 on 2 logic board, please note that the heat sink which was mounted on the case coming from the old board is mounted to a heat sink located on the new board and does not need to be mounted to the case.

## Troubleshooting

### ***Audio doesn't work*** (Assumes No LEDS)

Outlet on?

Power supply plugged in?

### ***Lane 1 no incoming*** (Assumes incoming on position 2)

Adjust gain.

Doesn't work? Plug red connector into blue position.

Works, replace console.

Doesn't work, replace remote microphone.

Doesn't work, consult factory.

### ***Lane 1 no outgoing*** (Assumes outgoing on position 2)

Adjust gain.

Doesn't work? Plug red connector into blue position.

Works, replace console.

Doesn't work, replace remote speaker.

Doesn't work, consult factory.

### ***Lane 2 no incoming*** (Assumes incoming on position 1)

Adjust gain.

Doesn't work? Plug blue connector into red position.

Works, replace console.

Doesn't work, replace remote microphone.

Doesn't work, consult factory.

### ***Lane 2 no outgoing*** (Assumes outgoing on position 1)

Adjust gain.

Doesn't work? Plug blue connector into red position.

Works, replace console.

Doesn't work, replace remote speaker.

Doesn't work, consult factory.

### ***No incoming both lanes*** (Assumes power to console, LEDS work)

Remote connection cables plugged in?

Adjust gain.

Still doesn't work? Replace console speaker.

Still doesn't work? Consult factory.

### ***No outgoing both lanes*** (Assumes power to console, LEDS work)

Adjust gain.

Still doesn't work? Replace console microphone.

Still doesn't work? Consult factory.

24 POS. CONNECTOR 0691152  
 .025 FEMALE PINS 06952021

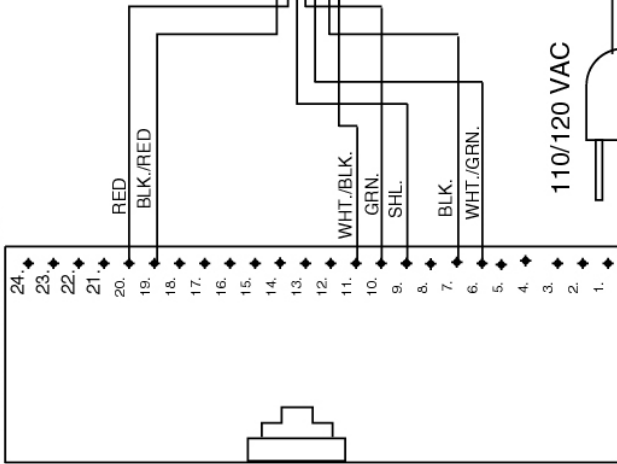

**BLUE 9 POS. PLUG**

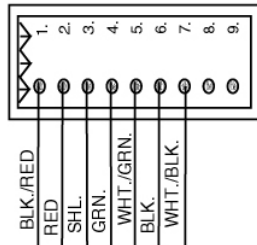

**WHITE CONNECTOR BOARD**

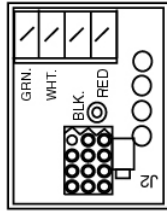

110/120 VAC

17 VDC  
POWERPACK

**RED 9 POS. PLUG**

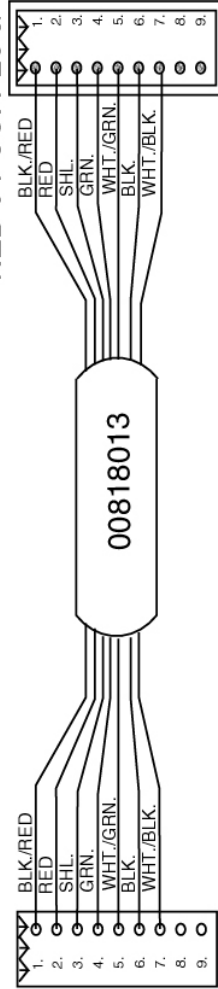

.093 FEMALE PINS 06953011

9 POS. RECEPTACLE 069951051

01611002 1 ON 2 CONSOLE

E.F. Bavis & Associates, Inc.  
 201 Grandin Road, Maineville, Ohio 45039 (513) 677-0500

VOLUME

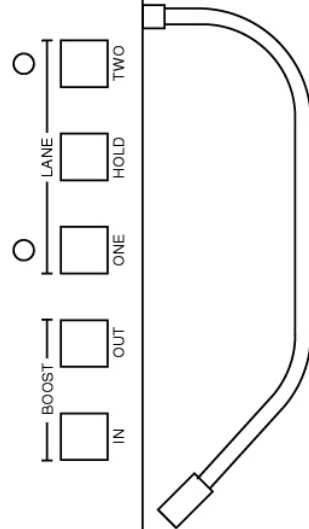

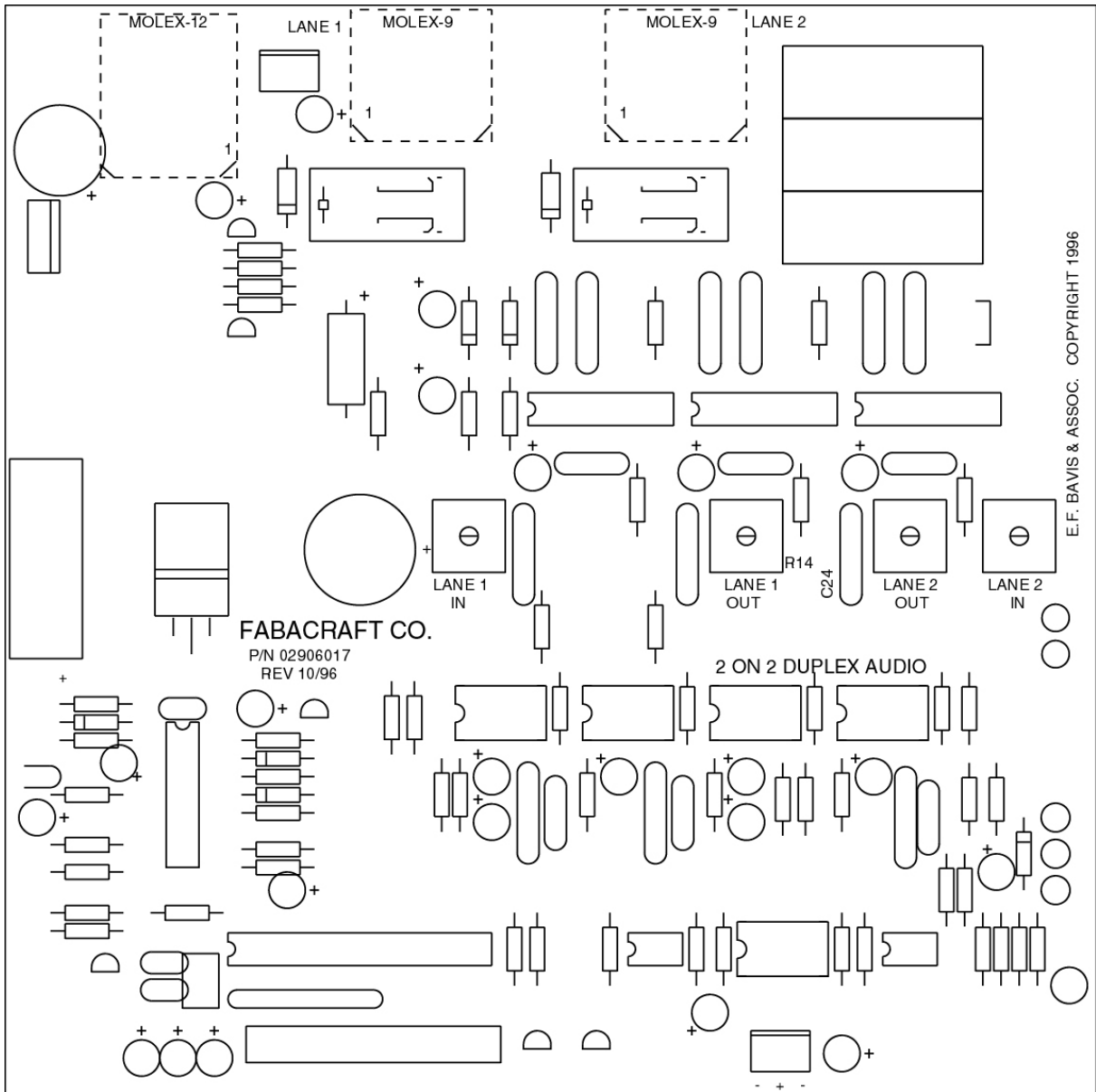



## Bavcom 2 on 2 Audio Systems **Adjustment**

It is necessary to open the console to adjust the gain controls. Access is gained by turning the two thumbscrews on the back of the console. The fasteners are captive and will not get lost or misplaced. After the fasteners are fully unscrewed the front portion of the case hinges forward for easy access.

Each position has separate gain controls and needs to be adjusted independently. For details on the location of the adjustments, see Fig. 2. The adjustment procedure is the same for each position.

With the teller speaking in the inside microphone and a car present at the customer unit, the outgoing gain control corresponding to that position should then be adjusted for satisfactory volume. The incoming gain control corresponding to that position should then be adjusted clockwise until feedback occurs, then counterclockwise until feedback stops. This should complete the adjustment. If the incoming level is not sufficiently high enough, the outgoing level will have to be reduced to be able to get additional incoming volume level. The gain levels are a balance; adjustment of each has an effect on the other. If the incoming level is too high, adjust it to a lower level. Reassemble the console. **Note: The incoming volume knob should be all the way clockwise for this procedure.**

With a lane selected, press the **boost in** button. The incoming should get substantially louder while the outgoing is muted. Press the **boost out** button. The outgoing should get substantially louder while the incoming is muted. If feedback occurs, consult the factory.

## **Board Replacement**

When replacing the 2 on 2 logic board, please note that the heat sink which was mounted on the case coming from the old board is mounted to a heat sink located on the new board and does not need to be mounted to the case.

# 2 on 2 AUDIO WIRING

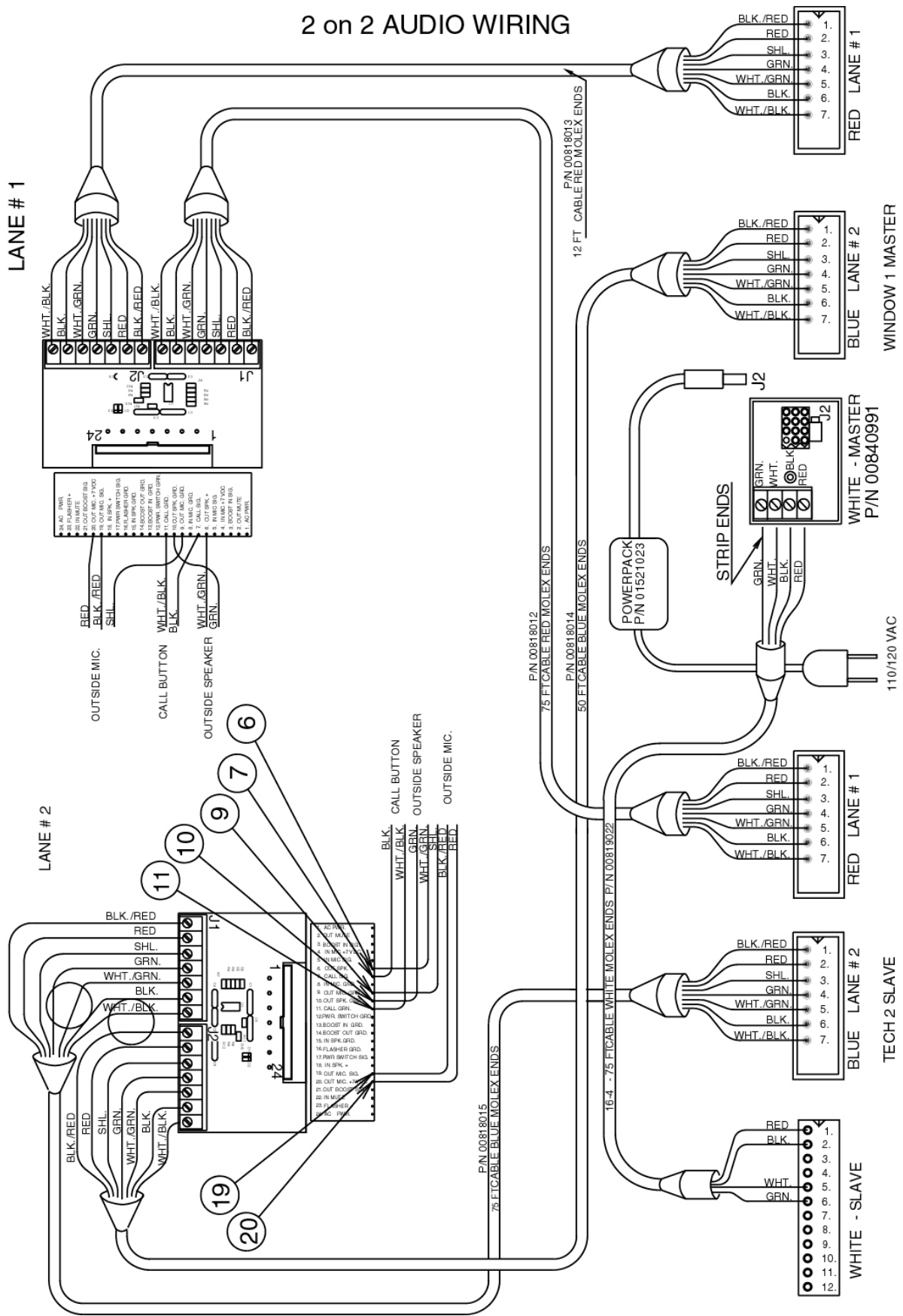

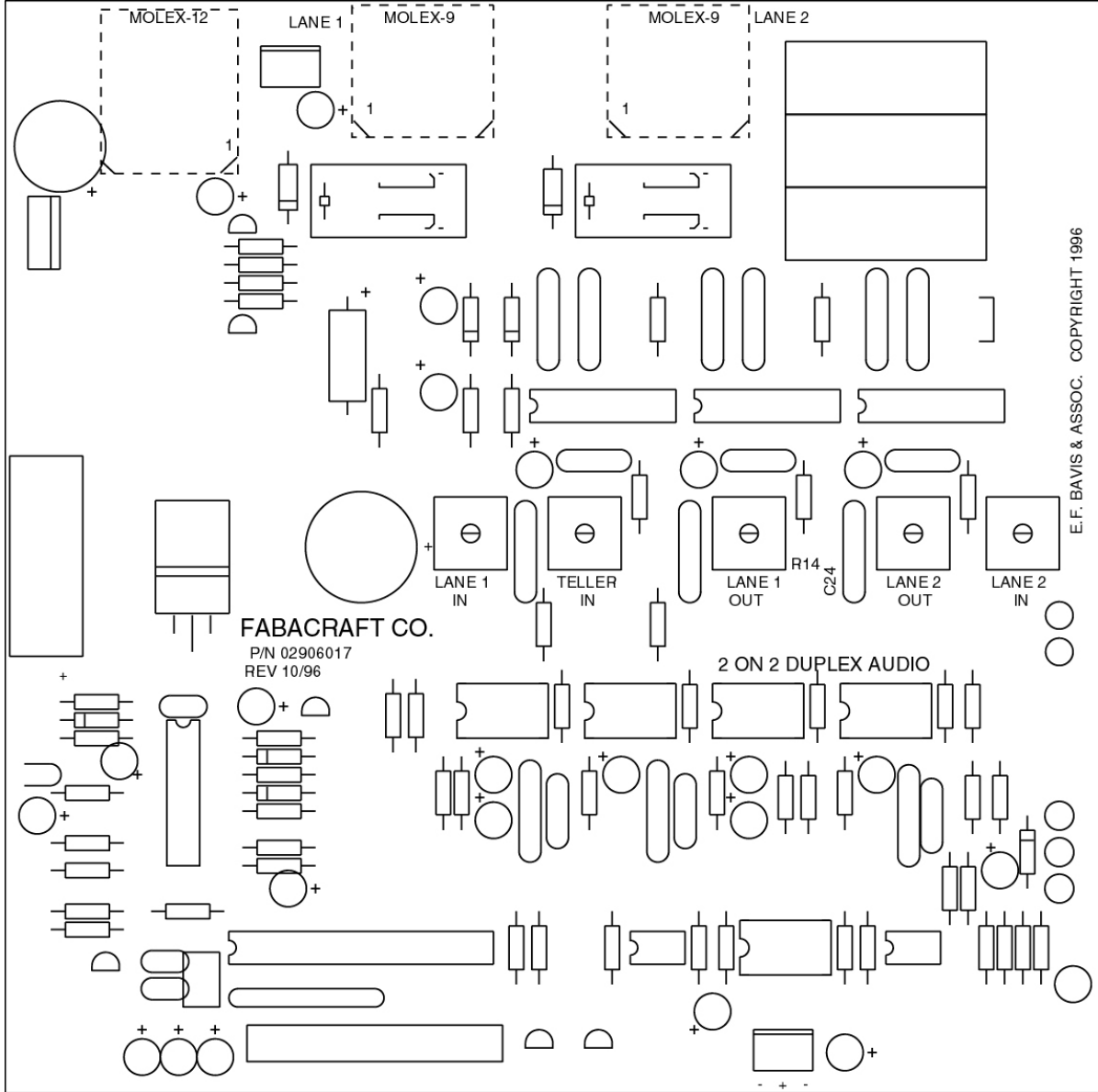

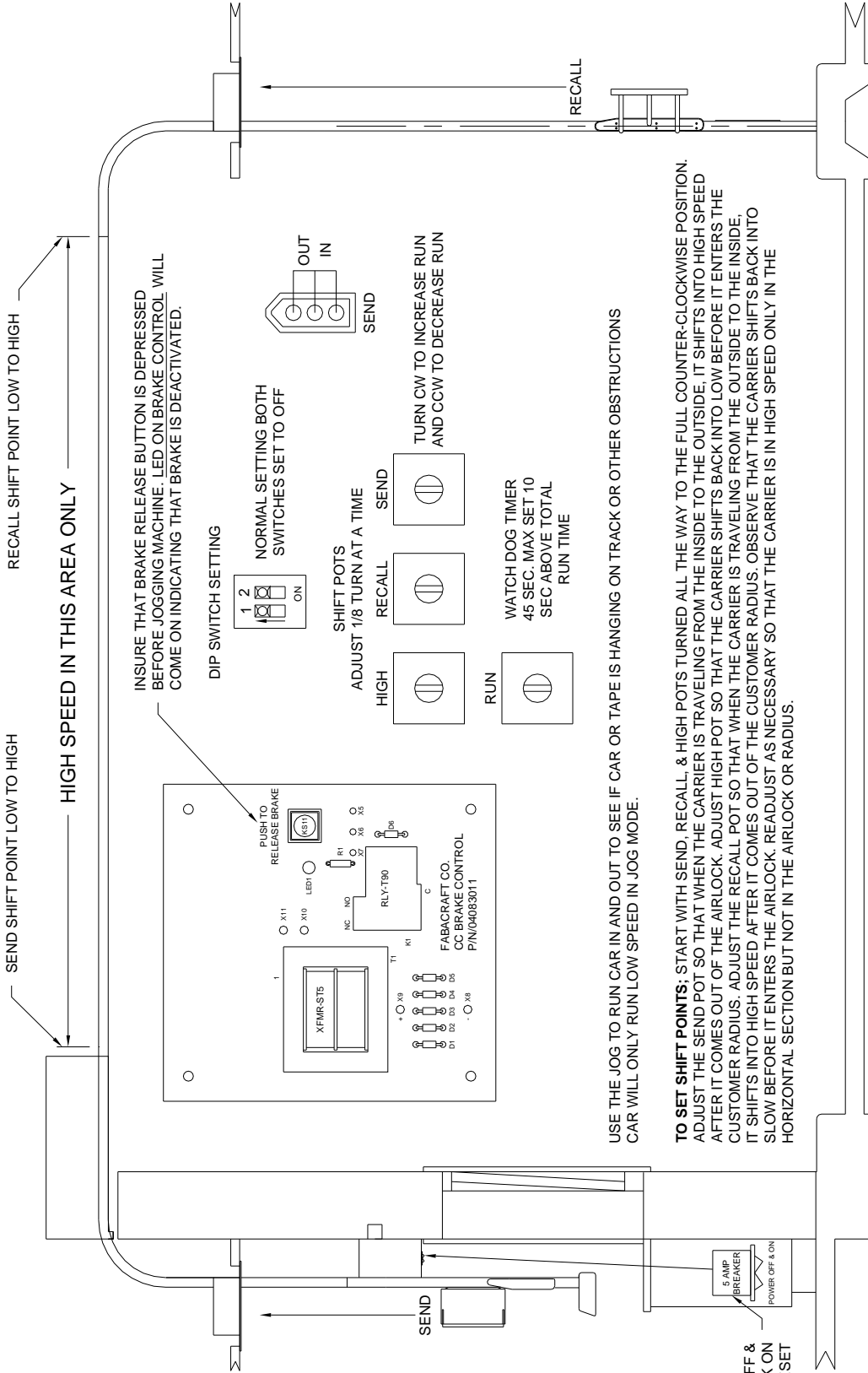

RECALL SHIFT POINT LOW TO HIGH

HIGH SPEED IN THIS AREA ONLY

SEND SHIFT POINT LOW TO HIGH

INSURE THAT BRAKE RELEASE BUTTON IS DEPRESSED BEFORE JOGGING MACHINE. LED ON BRAKE CONTROL WILL COME ON INDICATING THAT BRAKE IS DEACTIVATED.

DIP SWITCH SETTING

1 2  
ON  
NORMAL SETTING BOTH SWITCHES SET TO OFF

SHIFT POTS  
ADJUST 1/8 TURN AT A TIME

HIGH  
RECALL  
SEND

TURN CW TO INCREASE RUN AND CCW TO DECREASE RUN

WATCH DOG TIMER  
45 SEC. MAX SET 10 SEC ABOVE TOTAL RUN TIME

USE THE JOG TO RUN CAR IN AND OUT TO SEE IF CAR OR TAPE IS HANGING ON TRACK OR OTHER OBSTRUCTIONS CAR WILL ONLY RUN LOW SPEED IN JOG MODE.

**TO SET SHIFT POINTS:** START WITH SEND, RECALL, & HIGH POTS TURNED ALL THE WAY TO THE FULL COUNTER-CLOCKWISE POSITION. ADJUST THE SEND POT SO THAT WHEN THE CARRIER IS TRAVELING FROM THE INSIDE TO THE OUTSIDE, IT SHIFTS INTO HIGH SPEED AFTER IT COMES OUT OF THE AIRLOCK. ADJUST HIGH POT SO THAT THE CARRIER SHIFTS BACK INTO LOW BEFORE IT ENTERS THE CUSTOMER RADIUS. ADJUST THE RECALL POT SO THAT WHEN THE CARRIER IS TRAVELING FROM THE OUTSIDE TO THE INSIDE, IT SHIFTS INTO HIGH SPEED AFTER IT COMES OUT OF THE CUSTOMER RADIUS. OBSERVE THAT THE CARRIER SHIFTS BACK INTO SLOW BEFORE IT ENTERS THE AIRLOCK. READJUST AS NECESSARY SO THAT THE CARRIER IS IN HIGH SPEED ONLY IN THE HORIZONTAL SECTION BUT NOT IN THE AIRLOCK OR RADIUS.

TURN OFF & BACK ON TO RESET



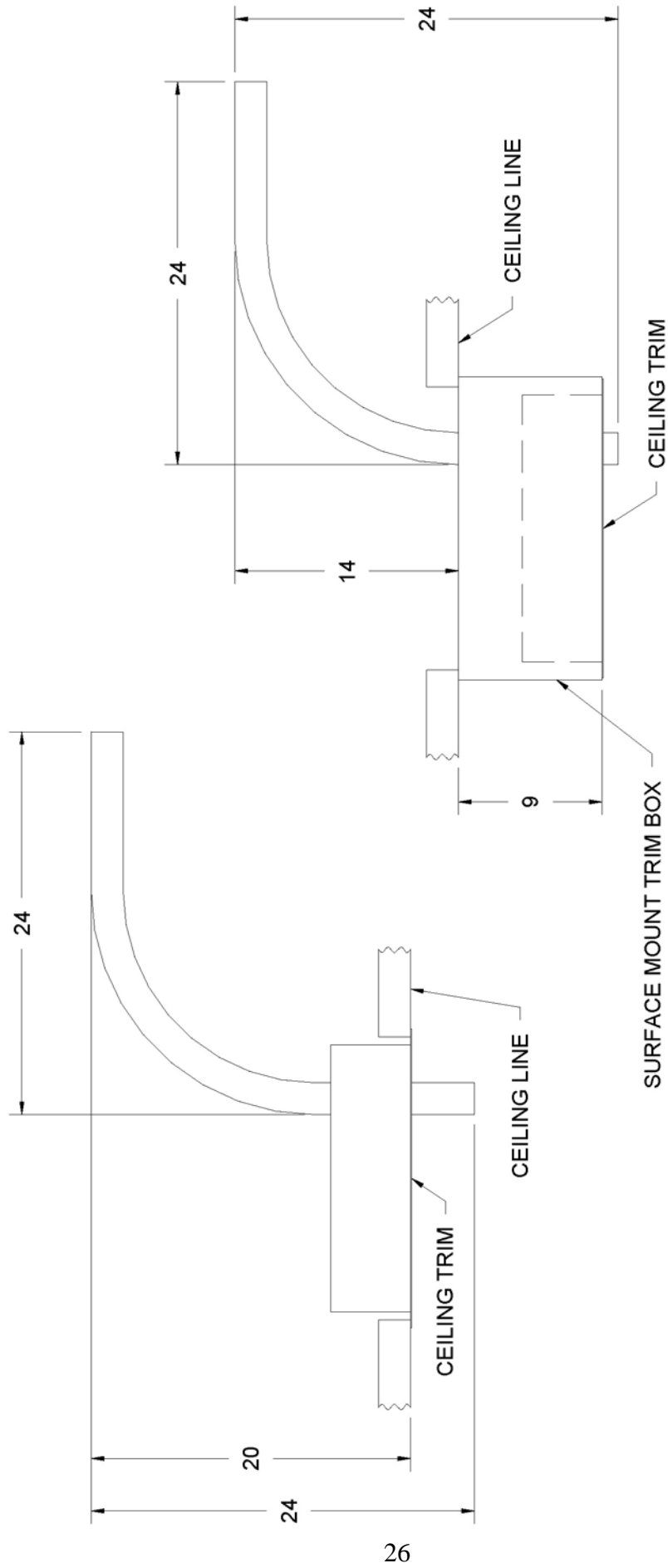

NOTE: TWO SURFACE MOUNT TRIM BOXES  
 CAN BE JOINED FOR 18" DROP OR  
 A SOFFIT CAN BE BUILT.

## Tools Necessary for Installation

Phillips head screwdriver #2 tip

Flat tip screwdriver, #1F2R tip (miniature)

Screwrunner, #2 phillips tip

Level

Tape measure

Half Round Bastard File 19/32 x 5/32 x 6

Power Miter Box with carbide tipped blade

Hammer Drill and Anchors

1/8 Shaft conical rotary cutter (Dremel tool preferred)

Serial # \_\_\_\_\_

## TransTrax® Captive Carrier Shipping Manifest

Part 04002995

<u>Qty.</u>	<u>Description</u>	<u>Part Number</u>
2	Horizontal Section 10'	04005591 _____
1	Inside Vertical Extension	04013195 _____
1	Inside Vertical Assembly	04013596 _____
1	Customer Vertical Assembly	04015596 _____
2	Hardened TT Radius	04016333 _____
1	Airlock Assembly	04017113 _____
2	Ceiling Trim Assemblies	04021224 _____
1	Horizontal Wiring Harness	04024112 _____
1	Car Assembly	04059991 _____
1	Warranty	
1	CC Trax Documentation Manual	00601012 _____
1	Roll of Coated Drive Tape	06820191 _____
In Double Bag:		
1	Customer Base	04023011 _____
1	CC Splice Plate 24 Pack	04058992 _____
1	Power Cord	02926031 _____
6	1" corner brace	01008492 _____
1	Bag of Splice Plate Screws	04224011 _____
1	Romex Connector	06926011 _____
2	9/64" Short drill bit	55555237 _____
1	Dremel Cutter	01081021 _____
2	#8-32 x 1/2 Truss Head Screws	93082723 _____
1	Electrical Tape	22016011 _____
12	#8 x 5/8 Sheet Screws	22016011 _____
2	#8-32 x 1-1/4 Phil Truss Head Screws with Locking Patch	93202723 _____

Motor/Machine S/N \_\_\_\_\_

Control Board S/N \_\_\_\_\_

Brake Board S/N \_\_\_\_\_



