



201 Grandin Road  
Maineville, Ohio 45039  
(513) 677-0500

# **CC Ceiling Trim Flap Manual**

---

Copyright 2017 E. F. Bavis & Associates, Inc.  
All Right Reserved

Revised: 11/20/2017  
PN: 00900294



## Table of Contents

Bill of Materials .....	1
Instructions .....	1
Assembly Diagram.....	2



## Bill of Materials

Part number	Description	Quantity
00900294	CC Ceiling Trim Flap Manual	1
04021053	CC Ceiling Trim Counter Weight	2
04038011	Flap Bushing	2
04048021	TT Flap Spring SS	2
04234591	CC Left Flap Assembly	1
04235591	CC Right Flap Assembly	1
55555319	5/64 Long Arm Allen Wrench	1

## Instructions

1. Remove the ceiling trim from the vertical tube.
2. Loosen the 8-32 hardware that holds the left and right halves of the ceiling trim together. Separate the two halves.
3. Remove the flap spring from both halves of the ceiling trim. Discard the springs.
4. Loosen the two set screws that hold the counter weight in place using the 5/64 long arm Allen wrench provided, (See Detail B of Assembly Diagram). Remove the counter weight. Do this for both ceiling trim halves.
5. On one half, loosen the 8-32 nut that holds the small axle in place (refer to Detail A of Assembly Diagram). Slide the axle out of the ceiling trim bushing. Do the same on the other half.
6. Twist the ceiling trim assembly flap up and remove from the ceiling trim frame. Do this on both halves.
7. Remove the ceiling trim bushing from both ceiling trim halves and discard.
8. Reverse steps 7-1 to install the new flaps. Make sure that the bushing that holds the spring to the counter weight is even with the counter weight axle and that the set screws are tight.

# Assembly Diagram

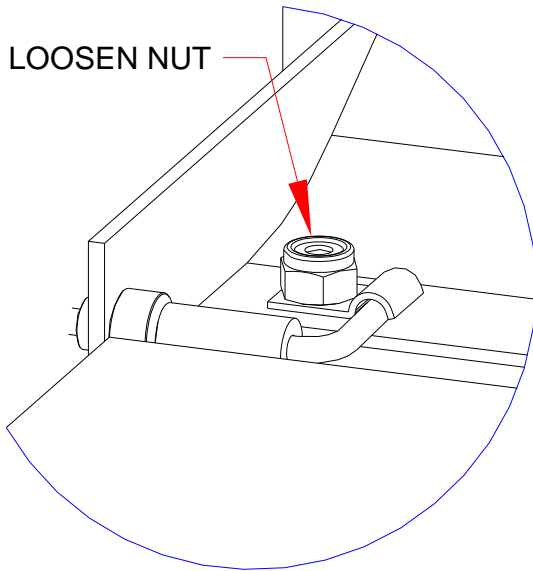
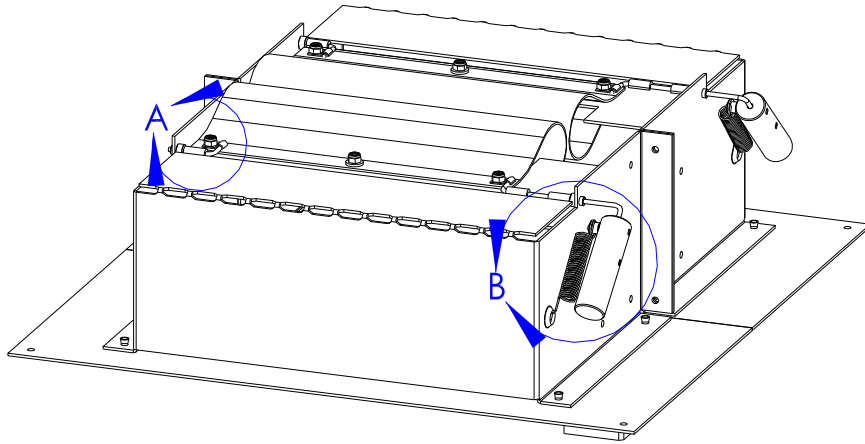

DETAIL A

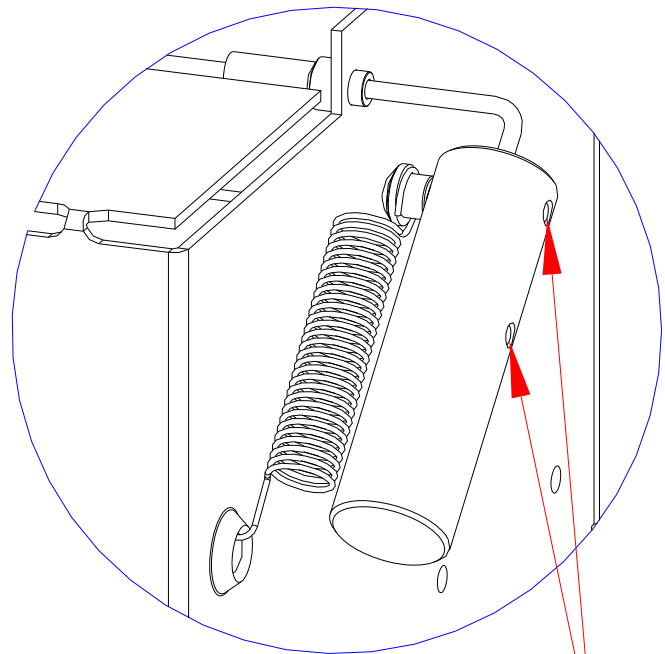

DETAIL B

SET SCREWS

