



201 Grandin Road
Maineville, Ohio 45039
(513) 677-0500

Cat5 Audio Connection Manual

Copyright 2016 E. F. Bavis & Associates, Inc.
All Right Reserved

Revised: 01/18/16
PN: 00900278

Cat5 Audio Connection Manual

Table of Contents

Overview	1
Installation of RJ45 Jack Assembly	1
Fig. 1 – Remove Cover.....	2
Fig. 2 – Wire Diagram.....	3
Fig. 3 – Insertion Tool	4

Overview

This kit is for the installation of a RJ45 jack to the end of a Cat5 cable, to allow for quick connection of Cat5 patch cables for audio and audio/video systems. The kit contains the tool to insert the wires into the RJ45 jack assembly, a section of two-faced tape and a screw, so the jack enclosure can be mounted to a wall, cabinet or other surface, if so desired.

Installation of RJ45 Jack Assembly

1. Determine a location for the RJ45 Jack assembly, and cut the Cat5 cable to the desired length.
2. Strip off approximately 1 inch of the outer jacket from the end of the cable using the tool provided, being careful not to nick the insulation of any of the twisted pair wires.
3. Remove the cover from the RJ45 Jack assembly. (See Fig. 1)
4. With the end of the outer jacket nearly even with the end of the terminal blocks, place each wire in the appropriate slot of the terminal blocks for a 568B connection. (See Fig. 2)
5. With the tool provided, press each wire to the bottom of the slot. (See Fig. 3)
6. Trim off the end of each wire even with the edge of the green circuit board, or so that the end of the wire is between the terminal block and the edge of the board.
7. Test the cable and connections, (if equipment is available).
8. Mount or secure the RJ45 Jack assembly, if so desired.
9. Re-install the assembly's cover.

Fig. 1 – Remove Cover

PRESS HERE AND PULL,
TO REMOVE COVER

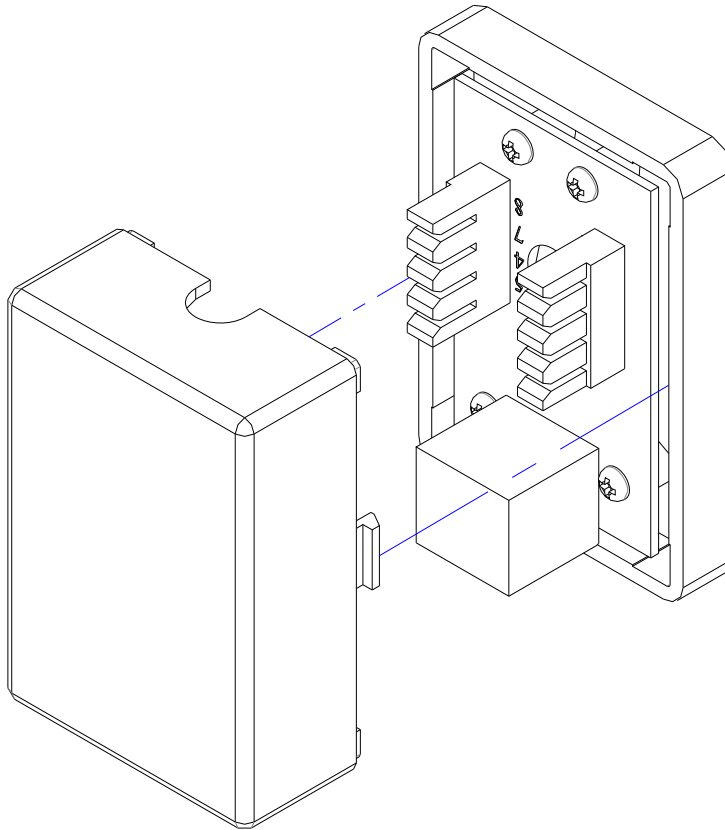
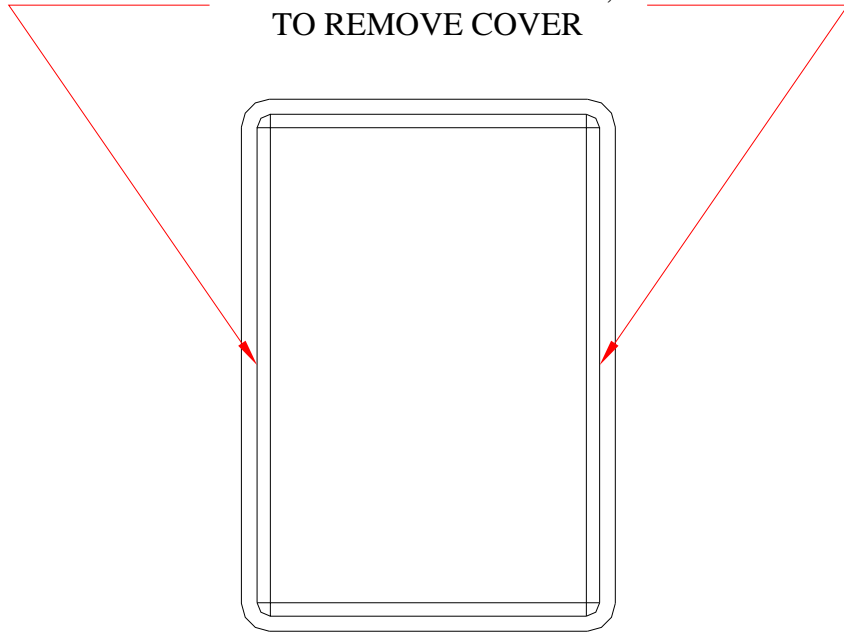

Fig. 2 – Wire Diagram

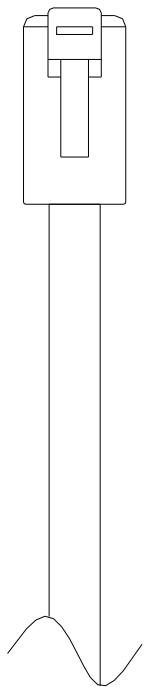
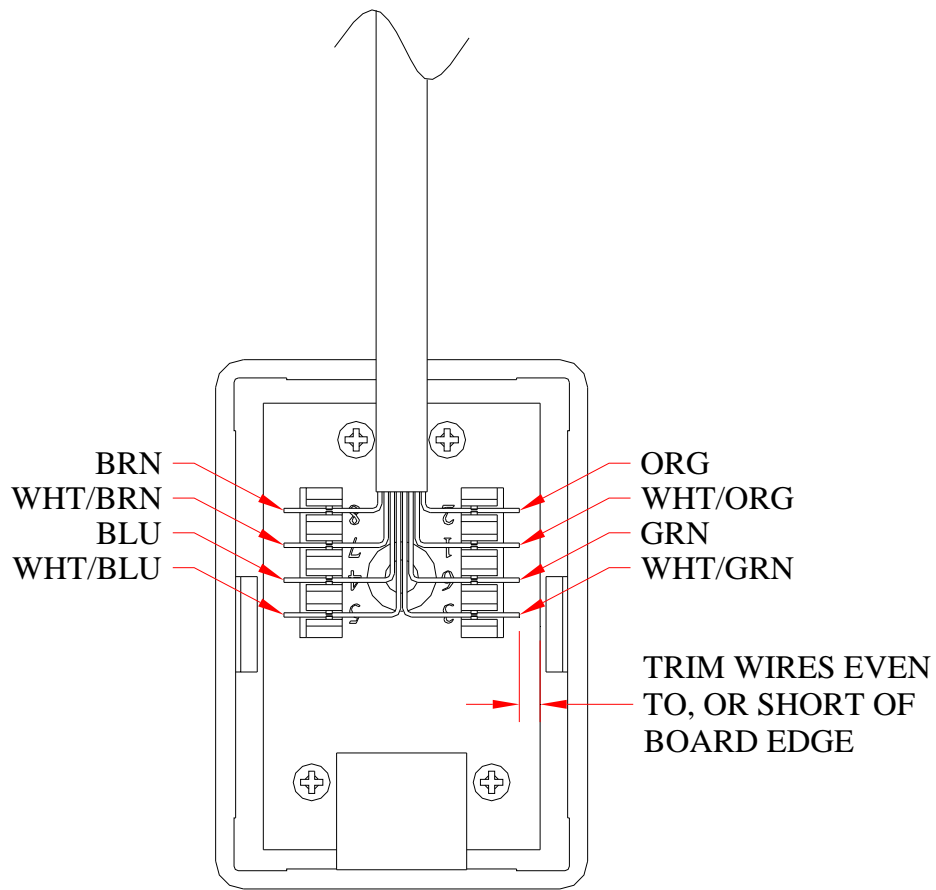

Fig. 3 – Insertion Tool

