

Red Sealed Start Button

The red start button is used on various products but it can also be used as a replacement for older products. The button is sealed which helps protect it from moisture.

The start button leads terminate in a connector which is connected to a short pigtail. Once you have installed the kit if you need to replace a button in the future you simply disconnect the old button and connect a new one. The pigtail also comes with two pigtail connectors to connect to the start function wires.

The red sealed start button comes with a brass nut, a molded nut and three reducing washers so it can be adapted to most any surface, hole diameter and material thickness.

If you have any questions please call the shop at 513-677-0500

Assembled with Brass Nut

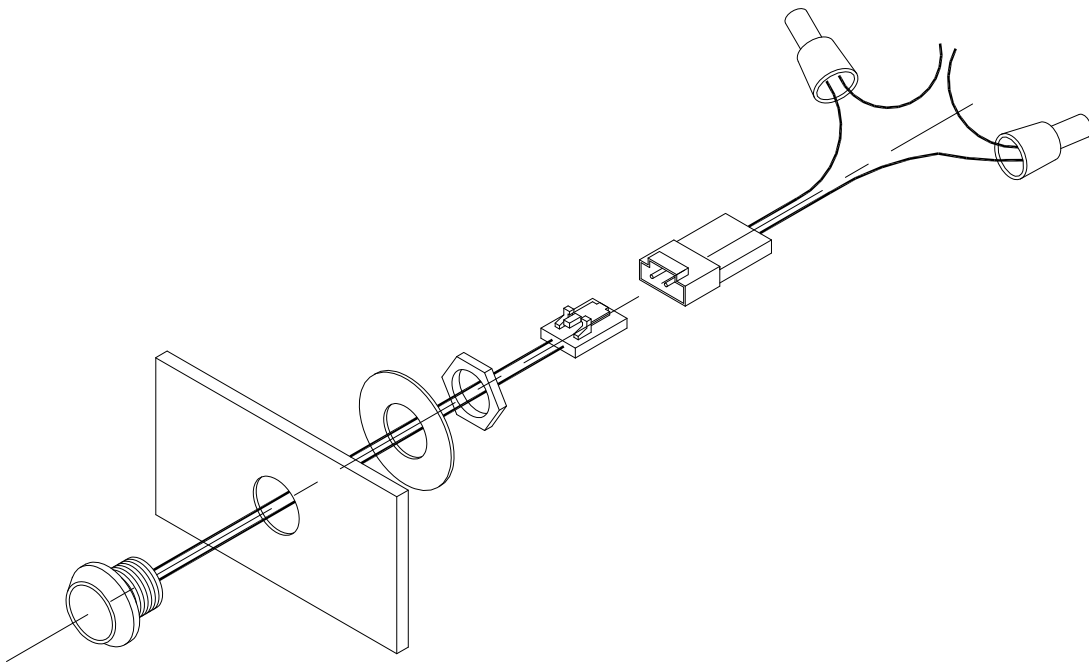

Assembled with Molded Nut

