AW JR Handset Installation Manual

E. F. Bavis & Associates, Inc.

201 Grandin Road
Maineville, Ohio 45039
(513) 677-0500

Table of Contents

Bill of Materials	1
Tools Needed.....	2
Installing Microphone Cables	2
Installing Speaker Wiring.....	3
Mounting Handset and Hook Assembly	5
Completed Wiring Diagram	7

Bill of Materials

**Part
Number**

Description

Quantity

Not Complete at This Time

Tools Needed

Medium Phillips Screwdriver
Drill
7/8" Drill Bit/Uni-bit/Hole Punch
Wire Cutters
Wire Connector Crimpers
#8 Spanner Bit
Electrical Fish Tape or Stiff Wire

Microphone Cables Installation

1. Remove the call button to gain access to wire chase.
 - To remove the button on older windows where the thin "Call Button" label is affixed directly to the face of the window frame, the button "snaps" into the face of the frame and can be gently pried out of the hole.
 - For newer windows that have a 1/8" plate between the "Call Button" label and the frame face, peel the label off of the plate to access the screws that hold the plate onto the frame.



2. Remove the microphone by removing the (2) screws in its flange.



3. Fish the two new mic cables through the call button hole up to the mic hole so that the connector on one cable is different than the connector on the other cable.



4. Connect one cable to the microphone lead and the other to the pre-amp/extension cable that runs back to the audio board.
5. Reinstall the microphone to the window frame.

Speaker Wire installation

1. Remove the speaker to access the wires.
2. Fish the two new speaker cables from the call button hole to the speaker hole leaving the ends of the cables with the two position connectors at the call button hole.
3. Measure 3 inches back from the speaker cover and cut the existing cable.

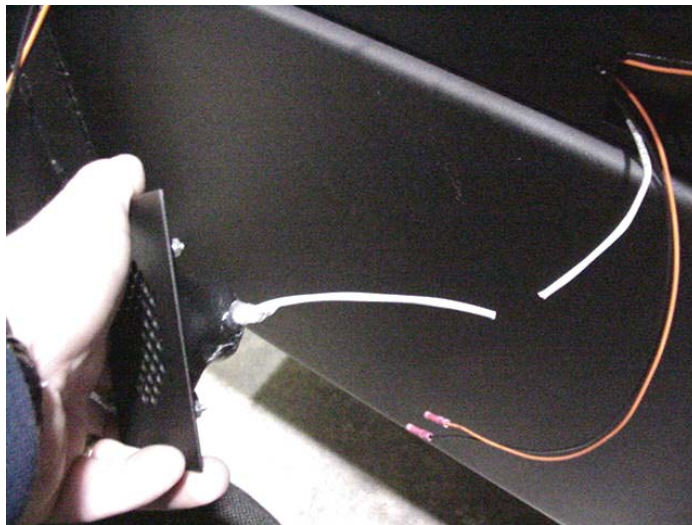

4. Using the inline splices provided, attach the cable with the small housing and female pins to the wires from the speaker.



5. Using the inline splices provided, connect cable with the large connector and male pins to the cable going back to the audio board.

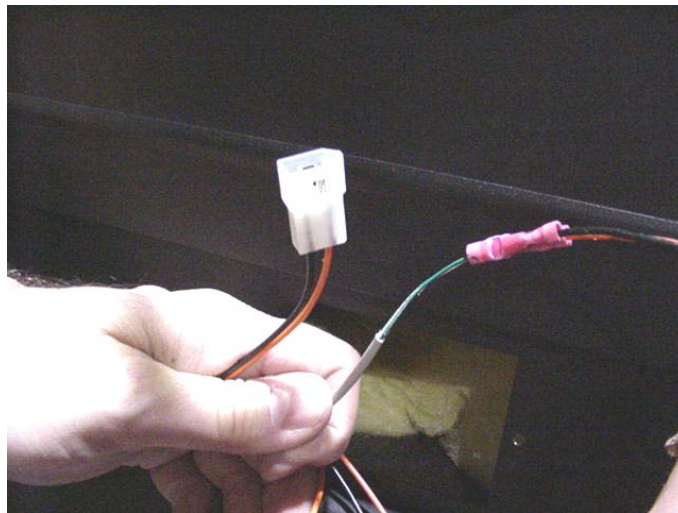

6. Reinstall the speaker.

Mounting the Handset and Hook Assembly

1. Before mounting the back plate, drill a 7/8" hole, 1-1/4" to 1-3/8" to the right of the center 7/8" hole to route the wires through.

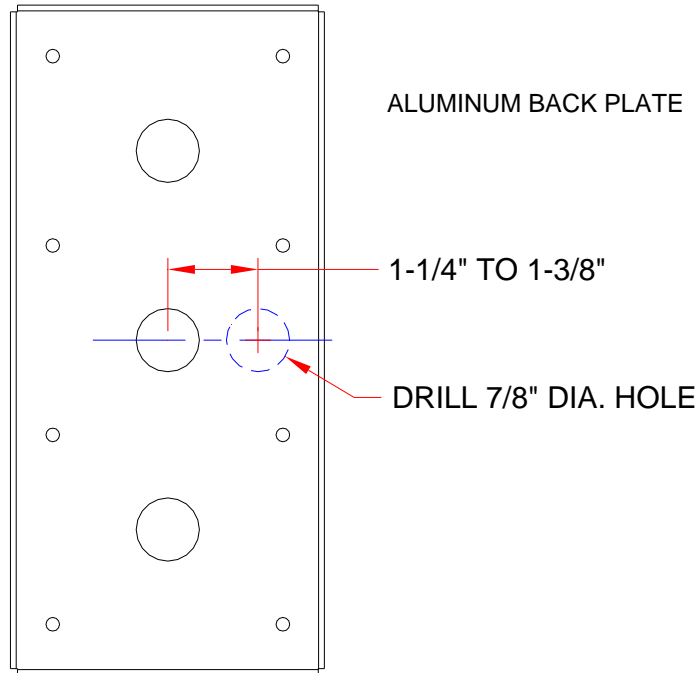

2. Mark, drill and mount the back plate to the window frame so the new 7/8" hole will align with the call button hole and there is approximately 3/8" or more space between the back plate and drawer's customer door.



3. Connect all wires to the appropriate connectors including the call button.

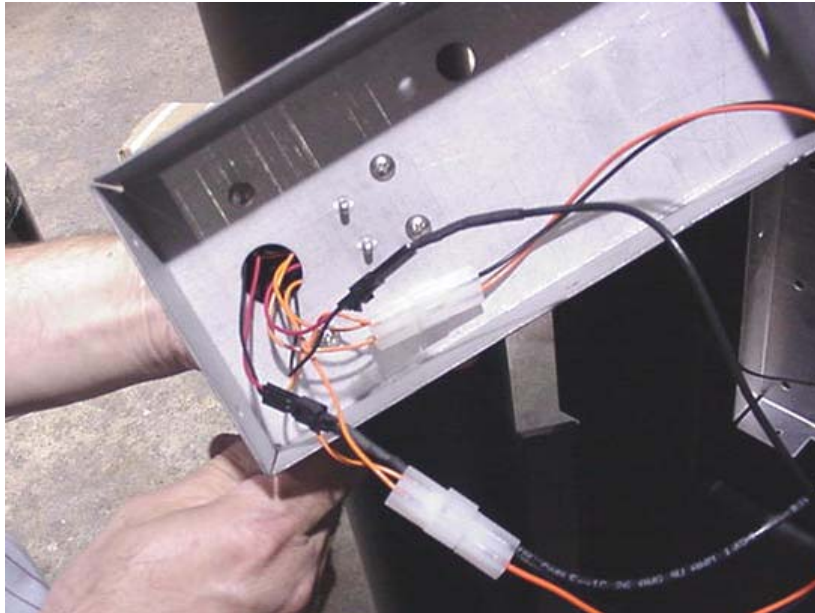

4. Tuck excess wire back into the window frame.
5. Mount the cover with the handset and hook onto the back plate.



6. Test audio system.

For additional help or information contact EF Bavis & Assoc. (513) 677-0500

Completed Wiring Diagram

