



201 Grandin Road
Maineville, Ohio 45039
(513) 677-0500

Tall Professional Work Station with POS Terminal and Monitor Mount Installation Instructions for P.N. 26000993 Work Station

Notice: This monitor stand will accommodate the following equipment:

- 1) Hewlett Packard LCD Monitor, Model HPL1910 (or similar sized LCD monitors with 100mm VESA mounting pattern)
- 2) Dynakey Unit: NCR Model 5952, NCR Model 5953, or NCR Model 5954

Please read any and all warning labels affixed to the machine.

Materials List:

The following items are included with the workstation and must be used during installation:

Part Number: 55555292	9/64 drill bit	Qty = 1
Part Number: 94101128	#10 base mount screws (Designed for particle board)	Qty = 3
Part Number: 92062205	#6-32 Dynakey mount screws (Nylon finger screws)	Qty = 4
Part Number: 26030011	Velcro Wire Ties	Qty = 3

Required Tools & Hardware:

1. #2 Phillips Head Screw Driver
2. Power Drill
3. Qty = 4 Black screws for mounting PC monitor. (provided by monitor manufacturer)

Mounting Base to Countertop:

1. This device is designed to be mounted to a one inch or thicker counter system.
2. Particleboard type mounting screws and pilot drill bit are included.
3. Pre-assemble the workstation by placing the gas cylinder in the base, then lowering the keyboard assembly onto the cylinder, (**see Figure #1**).
4. Position the unit on the countertop and determine best mounting location, while keeping in mind the unit rotates about its base.
5. Mark the location of the mounting holes on the counter and pre-drill pilot holes. Please note that all three supplied screws **MUST** be pilot drilled with the supplied drill bit and installed in the base in order for the stand to have the strength required for operation.

Mounting Dynakey Unit:

1. This workstation was originally designed to accommodate either the NCR5952 or the NCR 5953 Dynakey unit, and was later adapted to the NCR 5494 unit.
2. For a workstation using the NCR 5952 you must remove the plastic wire connector cover on the rear of the unit. This cover will interfere with the fit of the rear mounting brackets if not removed.
3. The brackets that accommodate either unit can be positioned in a low, middle, or high position. The spacing between positions is 1 inch. The workstation comes assembled with the Dynakey brackets in the middle position. If desired, the bracket hardware (4" carriage bolt, aluminum spacer, flat washer, adjustment handle, and two pivot bolt/nuts) can be removed, and reinstalled in the low or high position. In order to accomplish this, the PW Column Back

will need to be removed. Care must be taken to re-install the bracket hardware in the correct orientation (**see Figure #1**). Additionally, the two pivot bolts must not be over tightened or the angle adjustment will not work freely.

4. Once the desired bracket height is obtained, mount the appropriate Dynakey unit to the brackets with the supplied 4 #6-32 nylon finger screws.
5. Please note that Both NCR 5952 and NCR 5953 Dynakey systems use the same brackets and that care must be taken to ensure the correct hole pattern is used. (See **Figure #2** for exact mounting pattern.)
6. Ensure all four screws are tightened appropriately.
7. Adjust the Dynakey angle by loosening the upper adjustment clamp, tilting the unit to the desired angle, and then re-tightening the upper adjustment clamp.
8. **The Angle Adjustment handle position can be changed by pulling the handle assembly straight out away from the support column and simultaneously rotating the angle adjustment handle to obtain desired handle position.**

Mounting PC Monitor:

1. This workstation is designed with three monitor height positions, low middle and high.
2. The workstation comes assembled with the monitor brackets positioned in the middle position. If desired, the bracket hardware (4" carriage bolt, aluminum spacer, flat washer, adjustment handle, and two pivot bolt/nuts) can be removed, and reinstalled in the high the low or high position. Care must be taken to re-install the bracket hardware in the correct orientation (**see Figure #1**) additionally, the two pivot bolts must not be over tightened or the angle adjustment will not work freely.
3. Remove the desktop stand per the monitor manufacturer's instructions.
4. Use the four #6-32 screws (supplied with monitor) in the rear of the monitor to mount it to the upper stainless brackets.
5. Ensure all four screws are tightened appropriately.
6. Adjust the monitor angle by loosening the upper adjustment clamp, tilting the monitor to the desired angle, and then re-tightening the upper adjustment clamp.
7. **The Angle Adjustment handle position can be changed by pulling the handle assembly straight out away from the support column and simultaneously rotating the angle adjustment handle to obtain desired handle position.**

Final Assembly:

1. Run Monitor and Dynakey cables down the front of the column and thru the hole in the keyboard tray, then secure wires with the supplied Velcro ties to the loops on the support column, (**see Figure #1**).
2. Use additional wire ties to manage loose wiring.
3. Ensure wires do not limit desired rotation of workstation.
4. Install keyboard, mouse, and remaining peripheral hardware. Please note that the workstation comes with both left and right handed mouse trays.
5. Adjust the overall workstation height by raising the height adjustment handle and assisting the unit up or down. Release the handle when the unit is at the desired height. Please note that due to natural cylinder force variations, the user may have to assist the unit in the upward or downward direction.

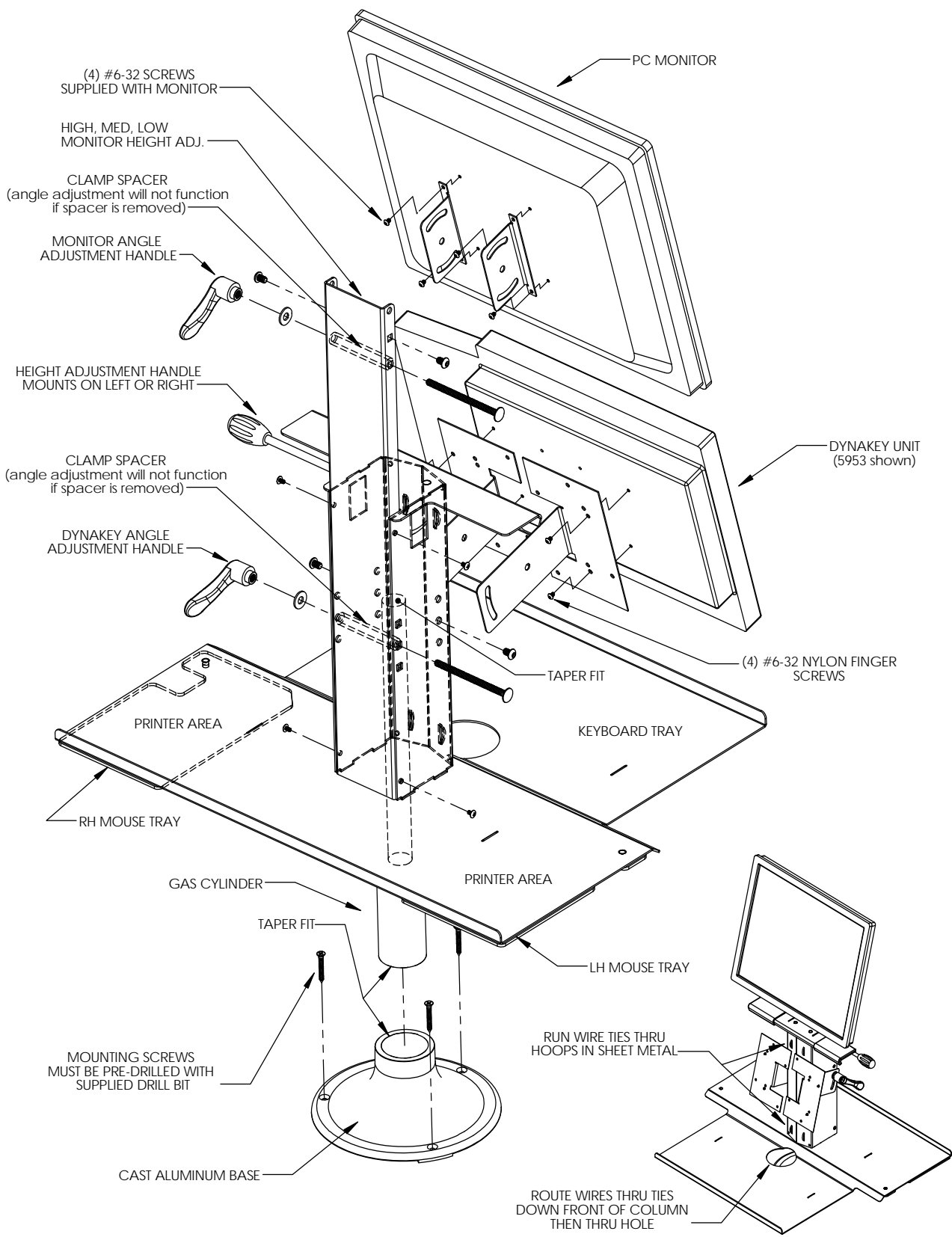
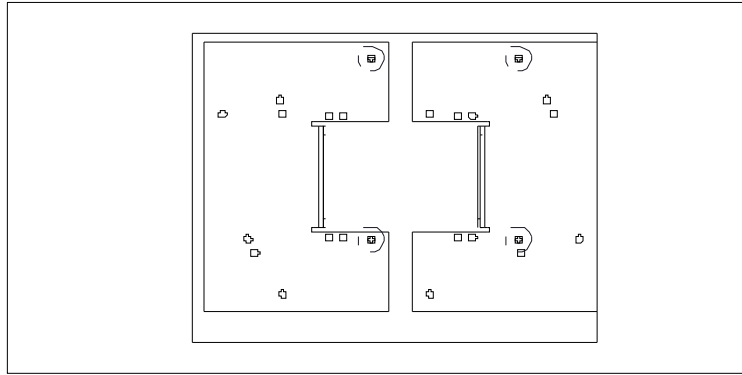
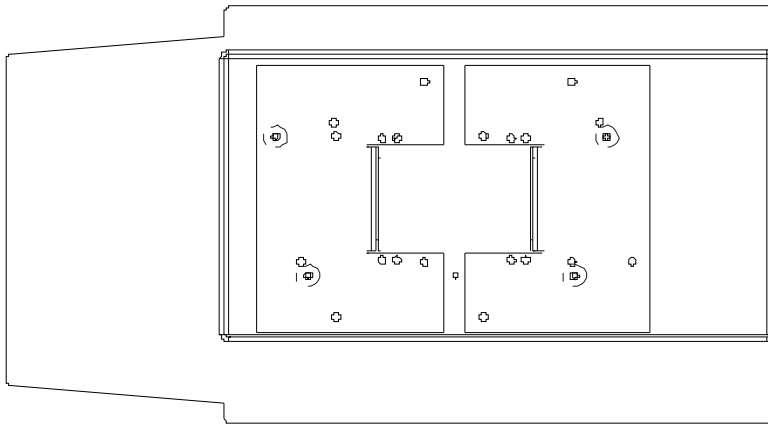

Figure #1

REAR VIEW: NCR 5952
DASHED CIRCLES INDICATE
MOUNTING SCREW LOCATIONS



REAR VIEW: NCR 5953
DASHED CIRCLES INDICATE
MOUNTING SCREW LOCATIONS



REAR VIEW: NCR 5954
DASHED CIRCLES INDICATE
MOUNTING SCREW LOCATIONS

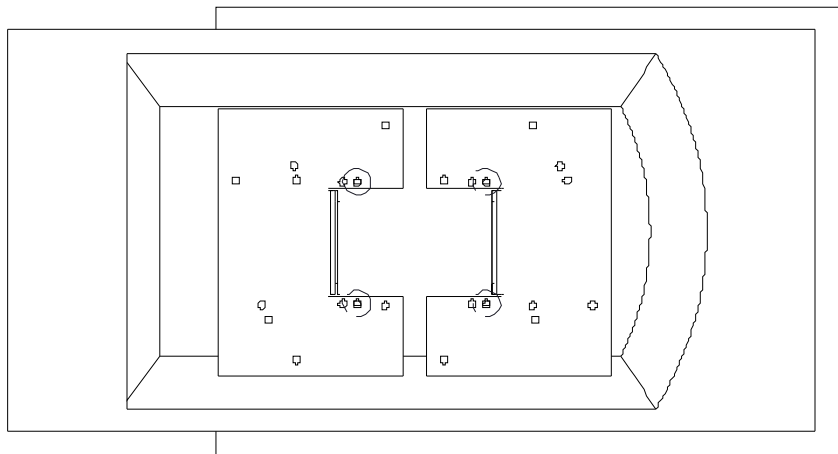

Figure #2

