



201 Grandin Road
Maineville, Ohio 45039
(513) 677-0500

TT Vehicle Detection Manual

Copyright 2018 E. F. Bavis & Associates, Inc.
All Right Reserved

Revised: 10/12/2018
PN: 00690022

TT Vehicle Detection Manual

Table of Contents

Vehicle Detector Programming	1
Installation Instructions.....	2
Board Connections & LEDs	3
Troubleshooting the LED Status.....	4
Customer Tube Illustration	5
Vehicle Detector Board Illustration.....	6
Vehicle Detector Board Mounting Option Illustration	7

Features

- Senses 3-dimensional changes to the Earth's magnetic field caused by the presence of ferrous objects.
- Compact, robust one-piece, self-contained sensor package replaces inductive-loop sensing technology.
- Designed to minimize the effects of temperature swings and destabilizing magnetic fields.
- Sensor learns ambient background and stores settings; sensor will not lose configuration or range when power is cycled.

Vehicle Detector Board Adjustments

When using this control board with the Bavis sensor, the two of potentiometers (pots) that can be adjusted control:

R3 – Controls how many times the chime will sound when it is activated, (1 to 4 chimes).

R4 – Controls the Volume of the chime tone.

Vehicle Detector Programming

The Bavis vehicle detection system can be installed into both window and remote drive-thru systems. When installed on windows, the sensor will detect vehicles in the first lane only. When installed on remote systems, the sensor can detect vehicles in both lanes if they are within the detection range of approximately a 7' diameter. There are both visual and audible indications of the presence of a vehicle. The visual indicator is a high visibility red LED, which stays on as long as a vehicle is present. The audible indicator is a true chime tone audio alarm, which sounds once when a vehicle is present and will not sound again until the vehicle leaves and another is detected.

Drive-thru systems that are equipped with this vehicle detection system require programming to function properly. The first step is to insure that no vehicles or large metal objects are near the sensor. Begin by pressing the vehicle detector program or "teach" button once. The teach button is located on the vehicle detector control board (P/N 08907011), which is located under the right side door of the TransTrax standoff (see pages 5,6) Both the LED and chime tone will come on 12 times as the sensor calibrates itself for the local magnetic conditions. The calibration is stored in non-volatile memory, and will not need to be reset after a power failure.

The sensitivity can be adjusted by pressing the teach button twice quickly in succession. The LED and chime tone will come on once every two seconds. This indicates a sensitivity level of one. Press the teach button once. The LED and chime tone will come on twice every two seconds. This indicates a sensitivity level of 2. You can repeat this process up to a sensitivity level of 6, the most sensitive position. You end the sensitivity-programming mode by pressing the teach button twice in quick succession.

Note that each time you perform the calibration adjustment the sensitivity is reset to the default level of 5. The calibration may need to be done anytime the local magnetic conditions change.

Note: Holding the "teach" button for more than 1 second will not allow the system to learn its surroundings.

Installation Instructions

Note: If the remote lane has a skin, this will need to be removed for the installation of the sensor and re-installed after completion. **The Vehicle Detector cannot be mounted to the skin because the skins movement can create a false trigger.**

Note: If TT Connector Boards (P/N 04112011) are present in the remote lane, remove and hardwire both the control and audio cables color to color (see page 3).

NOTE: The Vehicle Detector's field of detection cannot read through steel objects. The Vehicle Detector Sensor must be mounted rigid, as any movement of the sensor will likely cause either false or missed signals.

1. Power down the unit.
2. Remove the speaker plate assembly from the face of the customer unit.
3. Remove the single screw from the sensor mount.
4. On the dive-thru input side of the customer tube, layout the tube and drill the mounting hole with the 3/16" drill bit provided (see page 4). Insert the mount into the opening in the tube, slide down until the screw can be tightened to the mount.
5. Plug the horizontal cable into the sensor assembly.
6. Open both of the standoff doors to gain access to the inside of the standoff.
7. Using a fish tape, pull the horizontal harness from outside to inside. **Note: It may be necessary to cut a 6" pigtail from the end of the horizontal cable for easier pulling through the tube. This can be re-attached to the cable inside with the white pigtail connectors provided.**
8. Re-install the speaker plate assembly.
9. Choose the appropriate mounting option for the Vehicle Detector board (see page 6), and mount the board.
10. Plug the 4-position white Molex plug of the power harness into the TT Microprocessor board, and the 3-position black plug into the Vehicle Detector board (see page 5). **Note: If the unit has an internal audio system, the audio power plug will need to be removed from the TT Microprocessor board and re-installed into the power harness.**
11. Plug the horizontal cable into the Vehicle Detector board (see page 5).
12. Set the sensor (follow instructions on page 1).
13. Close the standoff doors.

If you have any questions, please contact the factory at 1-800-937-3322

Board Connections & LEDs

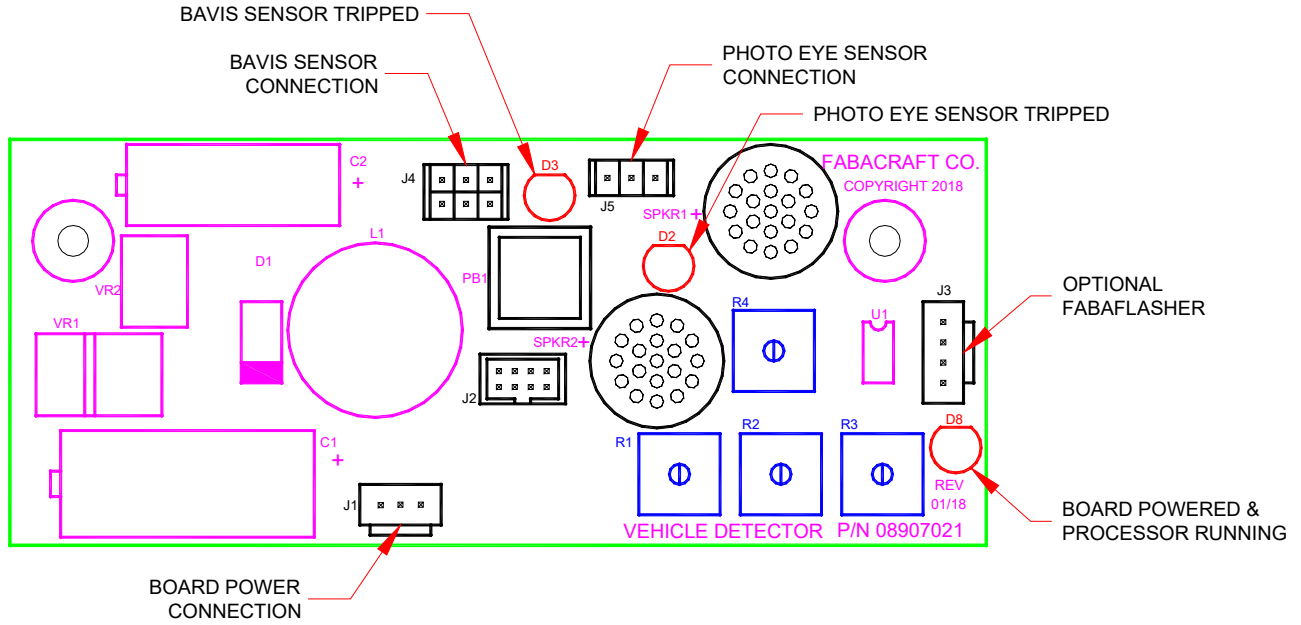

Teach Button & Adjustments

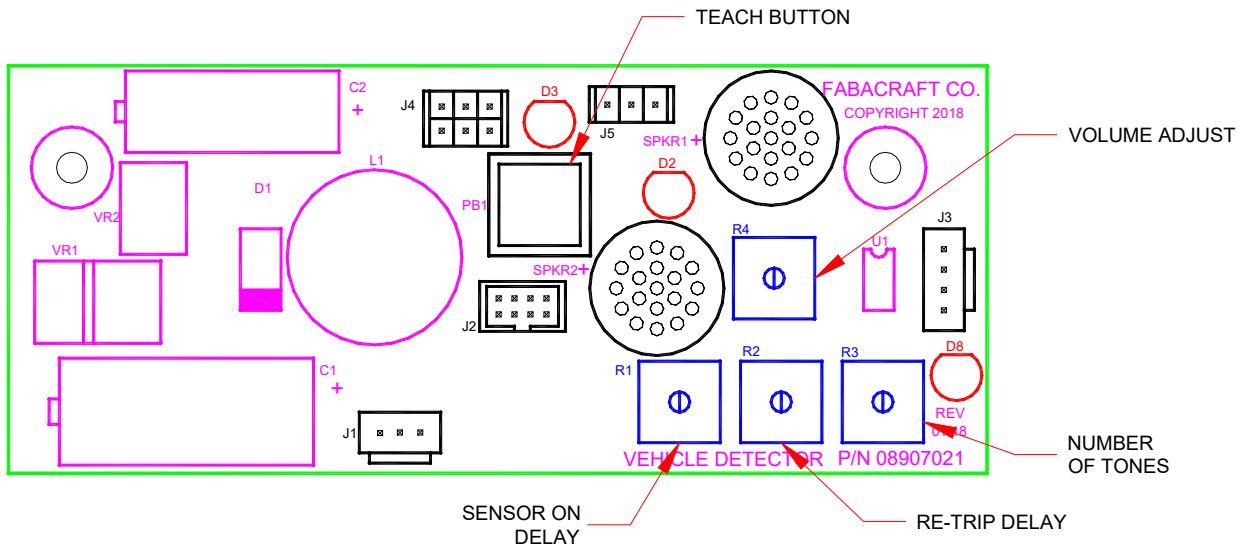

Troubleshooting the LED Status

Control Board LEDs

With Bavis Sensor - (D3) – Red
On – Vehicle Present
Off – No Vehicle Present

With Photo Eye – (D2) – Red
On – Vehicle Present
Off – No Vehicle Present

Power / Processor Running – (D8) – Red
Blinking – Board has Power and the Processor is running. If the Sensor has been tripped, (D2, or D3 is on), blinking will stop until the Sensor is cleared and the delay timers have run out their pre-set time and have reset.

Bavis Sensor Indicators

Sensor LED – Yellow
On – Vehicle Present
Off – No Vehicle Present

Sensor LED – Green
On – Power is on
Off – Power is off

Both the Control Board and the Sensor Yellow LED will flash during the calibration, (Teach) mode. (NOTE: The Sensors' Yellow LED will flash Red during the calibration, (Teach), mode.)

If both the Control Board and the Sensor Yellow LED are on steady with no vehicle present, the calibration, (Teach), procedure needs to be performed.

If you have any questions, please contact the factory at 1-800-937-3322

Customer Tube Mounting Illustration

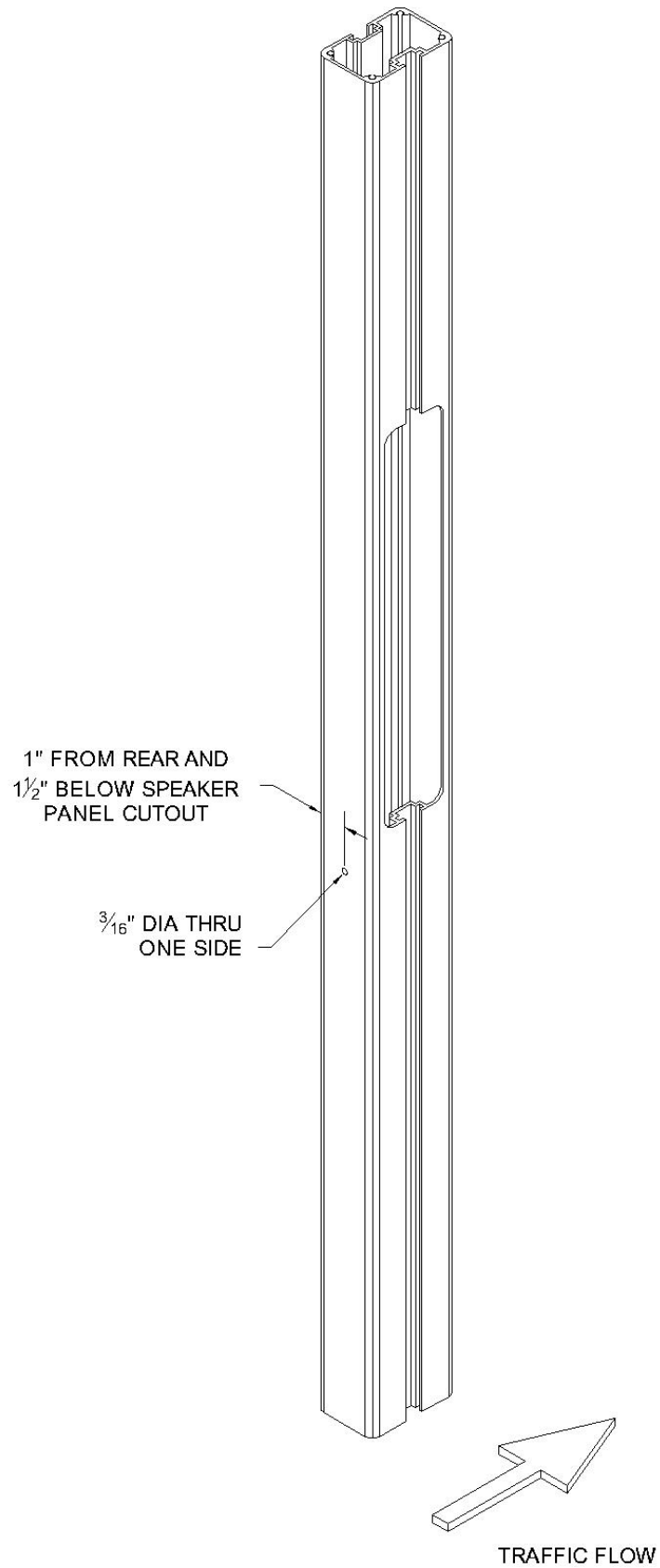

Vehicle Detector Board Illustration

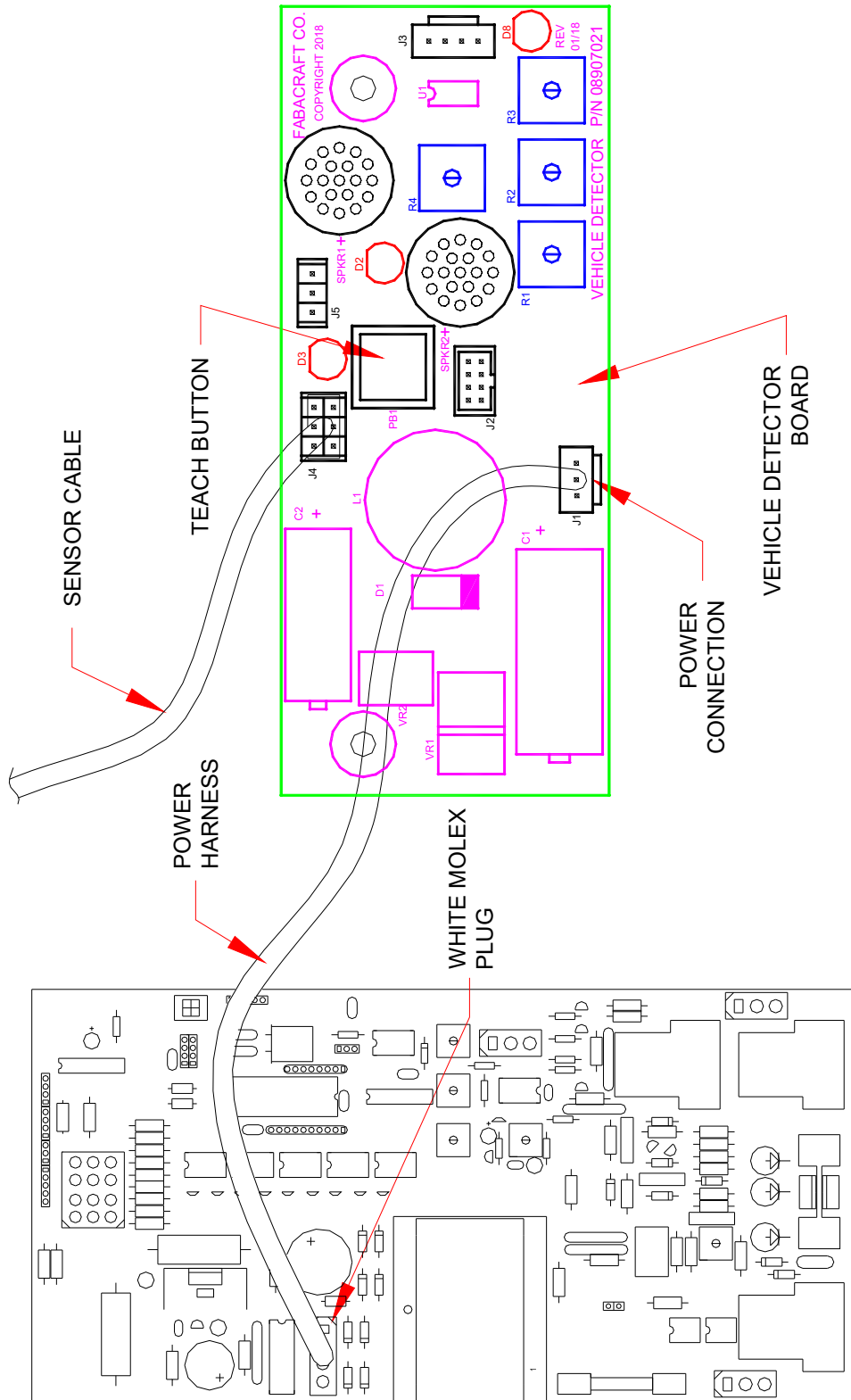

Vehicle Detector Board Mounting Option Illustration

