



201 Grandin Road
Maineville, Ohio 45039
(513) 677-0500

Transaction Drawer™

Installation and Service Manual

For Drawers with a Date Man. of, or before 3/17

Copyright 2022 E. F. Bavis & Associates, Inc.
All Right Reserved

Revised: 04/19/2022
PN: 00606011

Transaction Drawer™

Table of Contents

Important Safety Instructions.....	1
Grounding Instructions	1
Features.....	2
Installation/Service Information	3
Troubleshooting.....	6
Electrical Troubleshooting Diagram (Green or White Board)	8
Electrical Troubleshooting Diagram (Replacement Black Control Board).....	9
Exploded Parts Diagram	10
Parts List	11
Transaction Drawer Wiring Diagram - Early Version.....	12
Transaction Drawer Wiring Diagram – Thru Date Man. of 3/20	13
Transaction Drawer Wiring Diagram – Current Black Board	14
Installation Dimensions	15
Replacement Screw Diagram.....	16
Safety Bar Assembly.....	17
Lubrication Instructions	18

Important Safety Instructions

1. READ THESE INSTRUCTIONS.
2. KEEP THESE INSTRUCTIONS.
3. HEED ALL WARNINGS.
4. FOLLOW ALL INSTRUCTIONS.
5. DO NOT CLEAN THIS APPARATUS WITH A WATER SPRAY OR THE LIKE.
6. DO NOT BLOCK ANY VENTILATION OPENINGS. INSTALL IN ACCORDANCE WITH THE MANUFACTURER'S INSTRUCTIONS.
7. DO NOT INSTALL NEAR ANY HEAT SOURCES SUCH AS RADIATORS, HEAT REGISTERS, STOVES OR OTHER APPARATUS THAT PRODUCES HEAT.
8. ONLY USE ATTACHMENTS / ACCESSORIES SPECIFIED BY THE MANUFACTURER.
9. DISCONNECT POWER FROM THE APPARATUS BEFORE SERVICING.
10. REFER ALL SERVICING TO QUALIFIED SERVICE PERSONNEL. SERVICING IS REQUIRED WHEN THE APPARATUS HAS BEEN DAMAGED IN ANY WAY, SUCH AS LIQUID HAS BEEN SPILLED OR OBJECTS FALLEN INTO THE APPARATUS, THE APPRATUS DOES NOT OPERATE NORMALLY.

Grounding Instructions

1. THIS MACHINE MUST BE CONNECTED TO A GROUNDED METAL, PERMANENT WIRING SYSTEM; OR AN EQUIPMENT-GROUNDING CONDUCTOR MUST BE RUN WITH THE CIRCUIT CONDUCTORS AND CONNECTED TO THE EQUIPMENT-GROUNDING TERMINAL OR LEAD ON THE CONVEYOR.
2. DANGER-CHECK WITH A QUALIFIED ELECTRICIAN OR SERVICEMAN IF THE GROUNDING INSTRUCTIONS ARE NOT COMPLETELY UNDERSTOOD, OR IF IN DOUBT AS TO WHETHER THE APPARATUS IS PROPERLY GROUNDED.

Features

The *Transaction Drawer*[™] is a UL Listed, grounded, permanently connected, reciprocating conveyor system for use in package passing applications (patent no. 5,802,991). This conveyor is also classified under Banking Equipment with respect only to electrical fire, shock and casualty hazards. Burglary, theft protection and bullet resistant features have not been evaluated. The conveyor is designed to extend from the inside to the outside of a facility. The system uses a drawer that travels approximately 30 fpm with a maximum capacity of 25 pounds.

The device is rated 115 volts ac, 60 hertz, and 1 amp.

Adjustable stainless steel flanges are provided for mounting. The flanges can be adjusted from 1-1/2" above to 1" below the top of the drawer. Please refer to drawing 00500993 for installation dimensions. **Note: Use maximum 3/8" long screws when mounting the flanges to the drawer shell to prevent jamming. 8-32 x 3/8" thread forming screws provided.**

The drawer weighs less than 150 lbs. and can be shipped UPS or Federal Express to most locations.

A night latch is provided.

The drawer is constructed of heavy 11-gauge steel with a durable powder coated finish. Note that the top inside panel is made from stainless steel. Its large 25-pound capacity is suitable for commercial or convenience store transactions (up to two 12 packs of drinks).

The bin of the drawer is powder coated with a bright red finish and features a stop sign decal that is visible when the drawer is open. The drawer color and stop decal are designed to warn customers not to approach when the drawer is open.

Full 18" extension of drawer.

Full width bill/paper trap bar.

All of the pivot points that rotate less than 360° feature long life brass construction. All points that rotate more than 360° have high quality ball bearing construction.

No wiper or sliding type weather seals. Our seals are replaceable and operate in compression to reduce wear and provide the best possible protection from the elements.

There are no roller type drawer guides, which are easily jammed with paper clips and coins. The drawer guides are manufactured from a High-Tech lubricated material designed and built specifically for this application.

No belts or gearboxes are used. The *Transaction Drawer*[™] features a quiet direct shaft drive.

The DC drive features quick stop electronic braking action with the operating force electronically limited to 40 pounds. This also eliminates the need for troublesome limit switches.

A momentary switch with class II wiring is provided for operating the drawer. The switch is supplied with a mounting plate.

The switch location is up to the installer and can be on the top of the counter.

No fuses to replace. Overcurrent protection is provided by means of a 1 amp resettable circuit breaker, which is on the front of the drawer, accessible by the user.

There is a safety bar on the teller opening. This safety bar stops the outward movement of the drawer if there is anything caught between the teller door and the bin. The safety bar is self-resetting.

An optional customer audio panel with speaker, microphone and 1 call button is available in both a 2" deep for mounting on the wall surface and in a flat version that can be mounted flush to the wall. Either style can be ordered to work with the *BavSonic™* or *BavCom™* type audio system.

Optional manual operation kit is available.

Optional heater is available.

An optional Auto Recall Switch is available.

Optional Customer Door with Bumper, Stainless Steel Customer Door, or Stainless Steel Customer Door with Bumper are available.

Optional Bin Travel Limit kit is available

Please contact the factory part numbers and specifications of these items.

Installation/Service Information

CAUTION: If the back panel hex head mounting screws are exposed, and could catch clothing, replace them with the truss head screws provided (see page 12).

Customer Door Removal

To make installation of the *Transaction Drawer™* easier from the inside, it is possible to remove the customer door. Run the drawer out until the teller door is closed and the customer door pivot posts are exposed. Carefully remove the "E" clips and washers from each side. Take the arms off of the pivot posts by gently spreading the customer door actuator arms outward until they clear the pivot posts. Remove the customer door. Reverse the steps to reinstall the customer door. **Note that there should be one washer inside and one washer outside of each arm before reinstalling the "E" clips.**

Customer Door Seal works best if *Transaction Drawer™* is installed so the gasket on the customer door contacts the drawer's outer shell first, before contacting supporting wall or audio panel.

Servicing the Inside of the Drawer

Access to the inside of the drawer is through the back (Fig. 1). There are three screws on the face and two on the bottom that hold the back panel in place. The electronic controls are attached to the back panel under a watertight housing. There are wires from this housing that connect to the motor and the bottom of the drawer. After removing the screws, tilt the bottom of the back panel out until the water-tight housing clears the motor, then drop it down to clear the lip of the top panel. The panel can then be rotated 180° and secured with two of the screws back to the bottom of the drawer. This position will prevent excessive strain on the leads and components. Reverse this procedure to reinstall the back panel. **CAUTION - READ THE SECTION ON SERVICING THE ELECTRICAL CONTROLS BEFORE REMOVING THE WATERTIGHT HOUSING.**

Field Wiring Connection Box Removal

To make installation of the *Transaction Drawer*TM easier from the outside, it is possible to remove the field wiring connection box. Remove the cover from the box. Remove the back panel of the drawer. Remove the cable and strain relief from the box by loosening and removing the nut inside the box. Remove the machine screw from the inside of the electrical box that keeps it from rotating and the box will be free.

Switch Installation

The power present at the switch is at 24vdc, inherently limited to less than 100va, which by National Electrical Code is a class II level. In most areas, this jacketed wiring can be run open without the need for conduits. The wiring should be secured to prevent it from being pulled, disconnected, or damaged. Please refer to drawing on page 9 for complete wiring diagram.

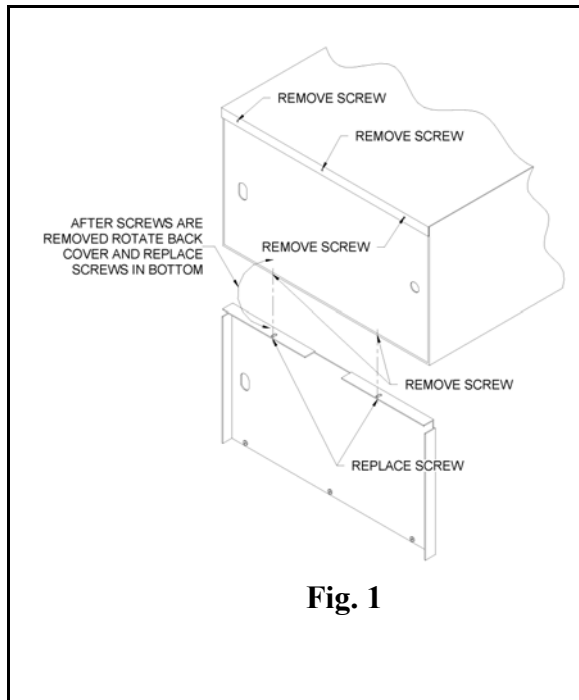

The switch is supplied with a mounting plate. The switch can be installed into the counter. If the switch assembly needs to be installed into the top or back of the *Transaction Drawer*TM, please contact the factory first.

Caution: Before drilling any holes, please check the backside of the location for the switch to insure that there is nothing in its way that would prevent the switch from being installed or the drilling would harm. The switch and wiring protrudes 1-1/4" into whatever it is mounted to.

Fig. 2 shows the proper dimensions for the hole layout to install the switch. Locate the center for the switch. The screw holes for mounting the switch plate are 3-1/4" apart. These holes will be on the centerline for the switch hole. The mounting plate holes can be pre-drilled at this time or marked and drilled after the switch hole is drilled. The hole for the switch needs to be 1-7/8" to 2" in diameter. An acceptable hole can be made with a spade bit or hole saw in countertop.

The operator switch electrical connection is via a 22-gauge 4-conductor cable. The cable and switch assembly are both equipped with mating 4 position connectors.

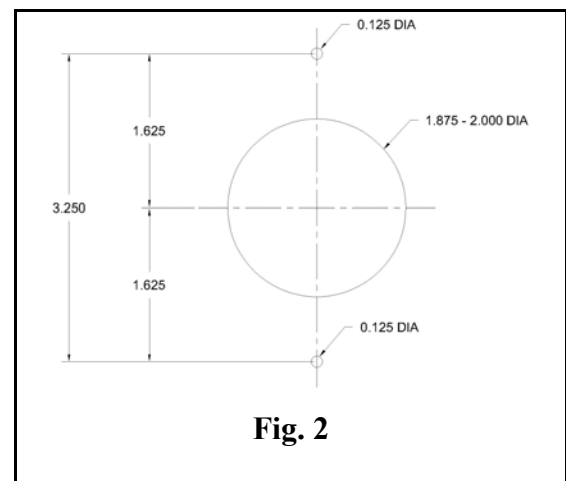

After making the electrical connection to the switch, test the drawer for proper operation. Normal orientation is such that when the switch furthest away is pressed, the drawer runs out. Place the switch into the hole and secure with the appropriate screws. Flat head sheet metal screws are provided for in-counter installation.

Field Wiring Connections

The device is rated 115 volts ac, 60 hertz, and 1 amp. The field wiring connection is via leads on the bottom of the drawer in a provided industry standard handy-box. The power connection should be made by qualified personnel in a workmanship like manner according to applicable national, state and or local codes having jurisdiction.

Drawer Removal

To remove the drawer it is necessary to disconnect the nut plate from the drive bar of the drawer. There are two 1/4-20 nuts that have to be removed. After the nuts are removed, the drawer can be slid out from the outside. **Note: After the nuts are removed, the Teller Door can push on the drawer and it may slide all the way out of the shell.**

Reinstalling the drawer is as simple as sliding the drawer back into position. The nut plate should be near the rearmost position. Insert the two 1/4-20 bolts of the drive bar through the bracket and re-install the nuts. **Note: After tightening the nuts, verify that the Red Bin is centered, left to right, in the guide track slot, at both ends of its travel. If the drawer binds or has no play, loosen the 1/4-20 bolts, readjust, tighten the 1/4-20 nuts and test again.**

Servicing the Electrical Controls

Warning - Risk of electrical shock - Disconnect power before servicing.

The electrical components are located under a watertight housing on the rear panel of the drawer. To maintain water-tightness, a gasket is attached to the panel under the housing. When servicing these components, be careful to not damage this gasket. When servicing is complete, replace all of the fasteners to maintain the integrity of the watertight seal.

There is a transformer that supplies the 36vac that the drawer operates on from the 115vac input power. A resettable circuit breaker is between the 36vac output and the control board. The control board supplies the 32vdc and electronic braking circuitry to the motor that runs the drawer. When the drawer is stalled out, the force goes to a maximum of 40 pounds at approximately 7vdc and .9 amps of power. The control board also creates a class II power circuit that connects to the switch, which allows the operator to run the drawer in and out.

The switch is momentary operation, when no direction is selected the board applies a dynamic brake to the motor which stops the drawer instantly and prevents creeping of the drawer.

The control board has failsafe devices that limit the power to safe levels in the event of a voltage regulator failure. If these devices have been tripped, the board must be returned to the factory for service.

Closing Drawer Manually

In case of a power failure, forcing the drawer closed can cause damage to the drawer. Without the manual operation option, the drawer can be closed by pushing slowly and evenly on the customer door so that it runs back inside.

Do not try to move the drawer by pressing or pulling on the Teller Door.

Troubleshooting

Drawer won't work...

Is AC power on? If not, restore power.

Breaker tripped? Reset breaker if tripped.

Is the drawer jammed? If the drawer is jammed, correct the problem.

Drawer won't run out...

Motor hums for both directions, - Check that the night latch is set to unlock.

Motor hums for IN but not for Out, - Check safety bar operation.

Drawer won't close fully...

Check that the night latch is set to unlock.

After completing the above, if a problem continues, contact a qualified service person to perform the following tests.

Problem	Action
Motor won't run	Check with meter for 36 – 42 Vac for 36V transformer and 28 – 33 Vac for 28V transformer at W1 and W2 on the control board.
No power to control board	Check circuit breaker for continuity with power disconnected.
No continuity through circuit breaker	Replace circuit breaker.
Continuity through the breaker but no power to control board	Check for 115Vac between the black and white wires at the base of the transformer. If the voltage is present, replace the transformer.
If the 36Vac or 28Vac is present at W1 and W2	Press direction button, listen to hear if a relay clicks. If relay clicks, check for motor voltage.
Relay does not click	Check for 24Vdc power between GREEN&WHITE, GREEN&BLACK and GREEN&RED wires at switch. Or, short from GREEN to RED, (drawer should run out), short from GREEN to BLACK, (drawer should run in). If no Click at switch, short wires at control board. If no Click there, replace the control board.
No 24Vdc power	Replace the control board.
24Vdc power is present	Check switch for continuity between terminals with wires disconnected and while activating switch.
No continuity through switch when "ON"	Replace switch.
Continuity when switch is activated	Check for 28 - 31Vdc to motor.
No voltage at motor when switch "ON"	Replace control board.
8Vdc at motor when switch "ON"	Check for jammed drawer.
28 - 31Vdc at motor when switch "ON"	Replace the motor.

Operator Switch Cable Functions;

White = +24Vdc.

Green = Vdc Common

Red = Run drawer out by shorting to Green wire

Black = Run drawer in by shorting to Green wire.

Note: DO NOT short White to Green

TRANSACTION DRAWER ELECTRICAL TROUBLESHOOTING DIAGRAM DATE MAN. 4/05 THRU 3/20 VERSION

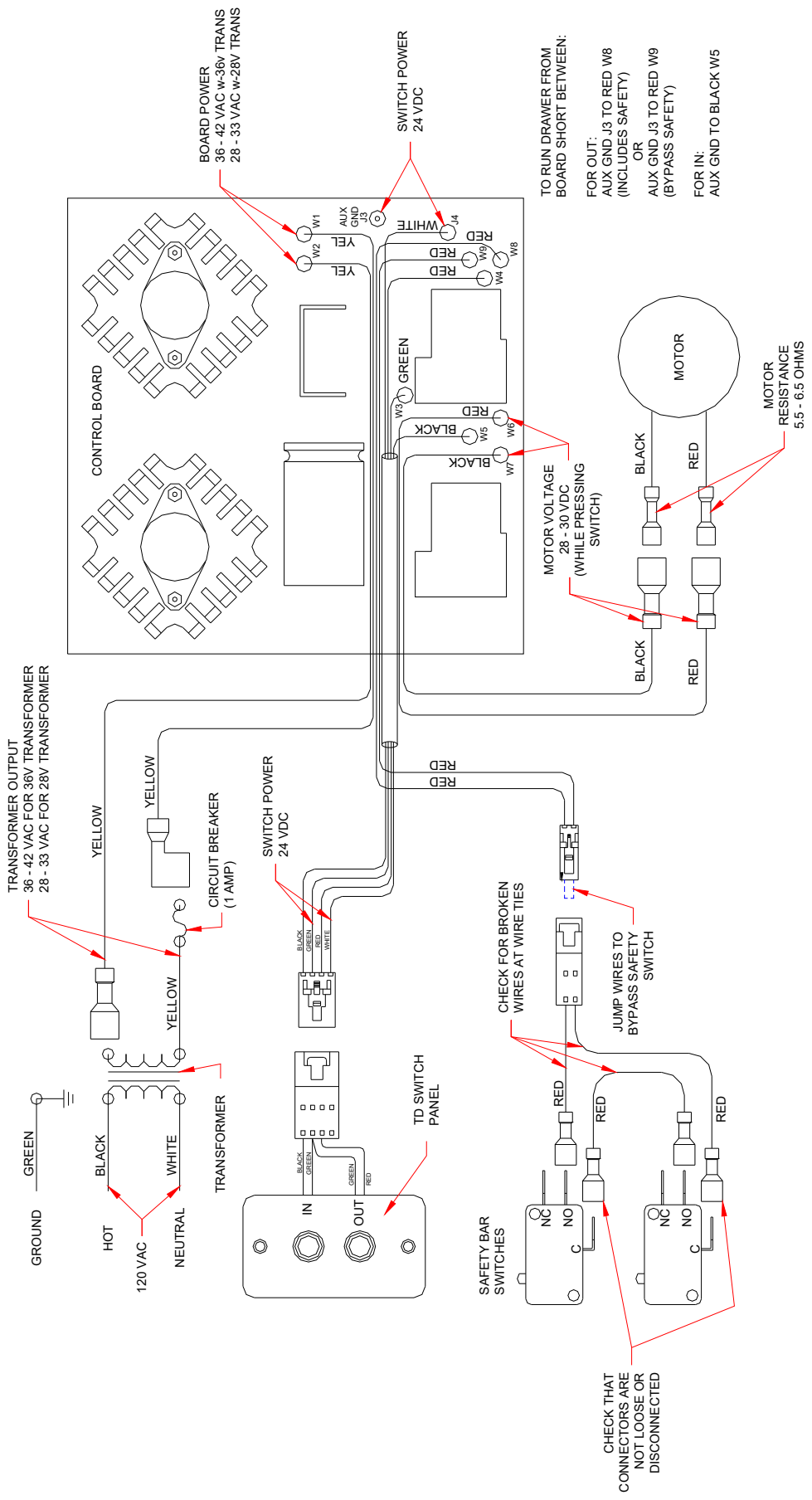

**TRANSACTION DRAWER
ELECTRICAL TROUBLESHOOTING DIAGRAM
REPLACEMENT BLACK TD CONTROL BOARD
P/N 00525013**

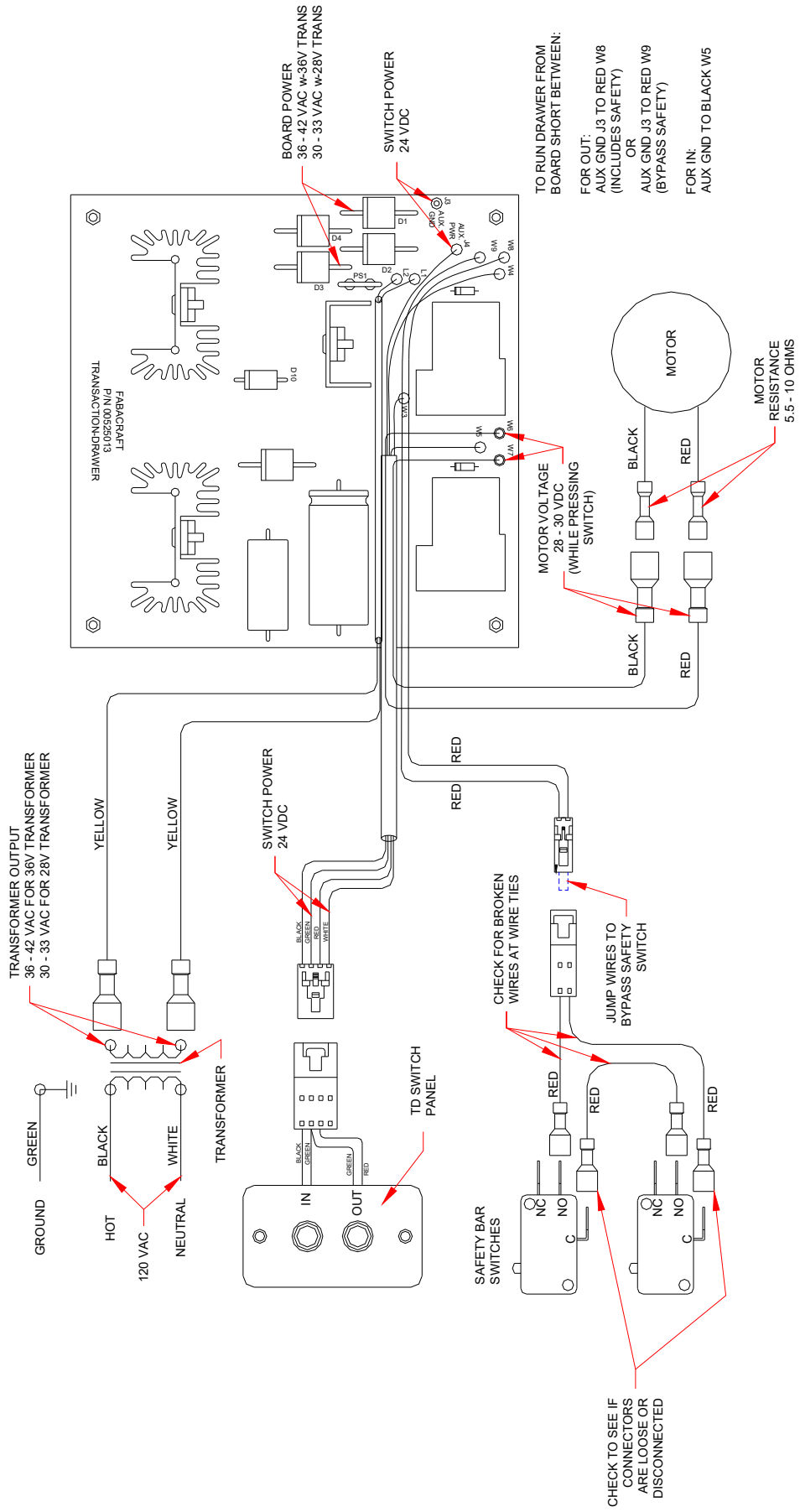

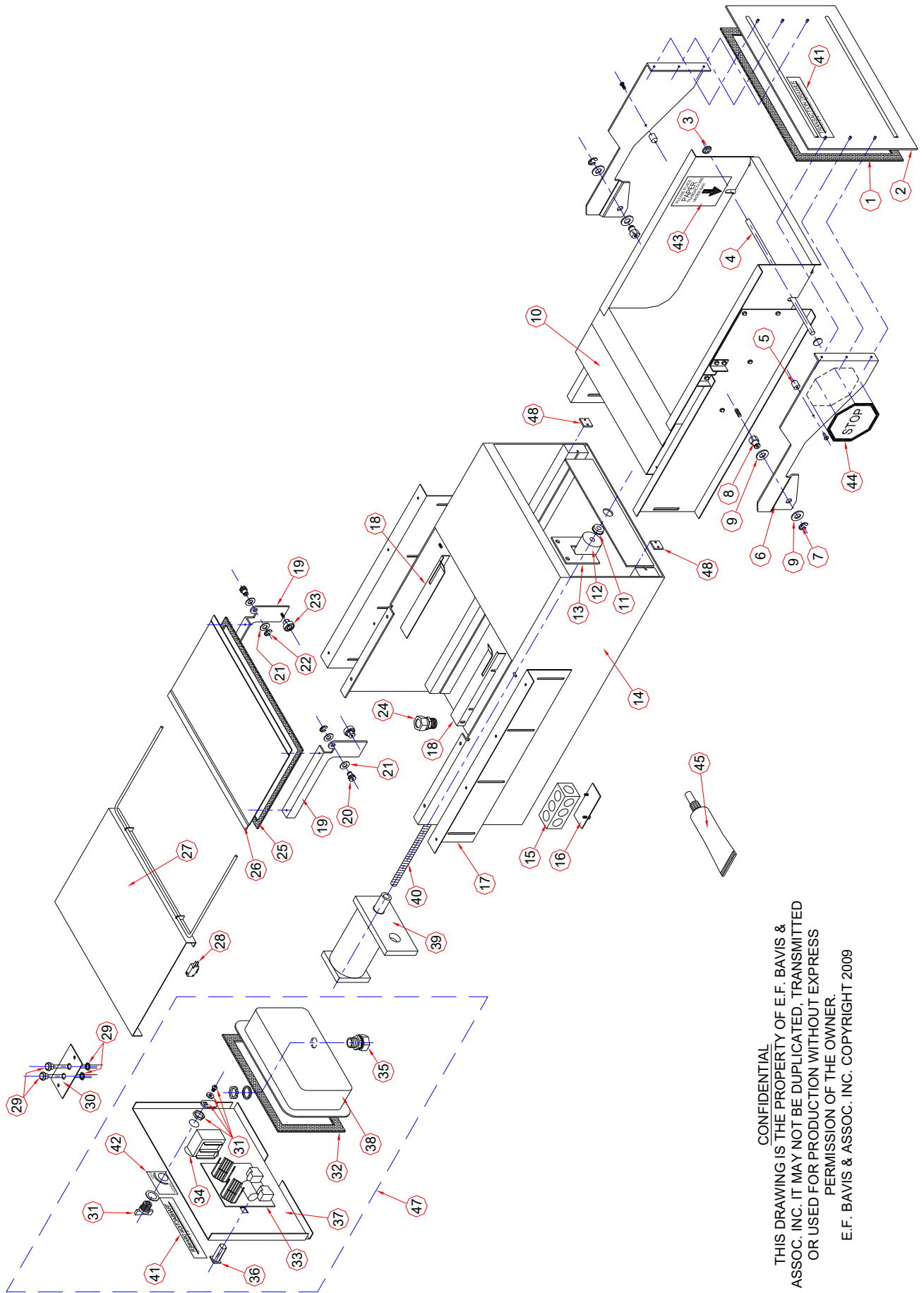

CONFIDENTIAL
 THIS DRAWING IS THE PROPERTY OF E.F. BAVIS &
 ASSOC. INC. IT MAY NOT BE DUPLICATED, TRANSMITTED
 OR USED FOR PRODUCTION WITHOUT EXPRESS
 PERMISSION OF THE OWNER.
 E.F. BAVIS & ASSOC. INC. COPYRIGHT 2009

ITEM #	PART #	DESCRIPTION	ALSO CONTAINS	QTY
1	00529021	TD CUSTOMER DOOR GASKET		1
2	00513991	TD CUSTOMER DOOR ASSEMBLY	1,41	1
3	97000073	3/8 SS PUSH CAP		2
4	00533991	TD BILL TRAP BAR KIT	3 (2)	1
5	00532012	MACHINE BRASS TD LIMIT PINS		2
6	00578991	REPLACEMENT TD DOOR ARM SET	5,7,9,44,46	2
7	98005071	1/2" E CLIP		2
8	00531012	TD CUSTOMER DOOR PIVOT POST		2
9	98006000	1/2 " SAE FLATWASHER		4
10	00521881	REPLACEMENT TD DRAWER RED TUB	3,4,8,13,43,46	1
11	00141013	3/8" BEARING WITH FLANGE		1
12	00502992	TD ACETAL NUT ASSEMBLY	13,46	1
13	00506191	TD NUT TO DRAWER MOUNT		1
14	00503991	TD SHELL ASSEMBLY	20	1
15	06969013	SMALL HANDIBOX		1
16	06937014	SMALL HANDIBOX LID		1
17	00534011	TD MOUNTING ANGLES SM		2
18	00535011	TD SIDE FILLER SM		2
19	00518992	TD TELLER DOOR PIVOT ARM (REPLACE WITH ITEM #26)		2
20	00530012	TD TELLER DOOR PIVOT		2
21	97006000	3/8" SAE FLAT WASHER		4
22	97005071	3/8" "E" CLIP		2
23	00591991	TD TELLER DOOR BEARING ASSY		2
24	06926061	0.25 - 0.375 STRAIN RELIEF		1
25	00529011	TD TELLER DOOR GASKET		1
26	24063991	TD REPLACEMENT TELLER DOOR ASSM	19(2),23,25,43,46	1
27	00523991	TD BACK TOP COVER ASSEMBLY	28	1
28	00305015	INTERLOCK SWITCH NO ARM		2
29	00319702	RED SEALED TD BUTTON W/LEADS		2
30	24053011	MOLDED 2 BUTTON SWITCH PLATE		1
31	00592991	TD LOCK KIT		1
32	00529031	TD ELECTRICAL ENCLOSURE GASKET		1
33	00590991	NEW TD BOARD KIT		1
34	00524013	TD 28V TRANSFORMER		1
35	06926041	0.375 – 0.500 STRAIN RELIEF		1
36	01085506	1 AMP CIRCUIT BREAKER		1
37	00520012	TD BACK PANEL SHEETMETAL		1
38	00542012	TD ABS RAIN SHIELD		1
39	00574011	TD REPLACEMENT MOTOR ASSEMBLY		1
40	24081991	TD THREADED ROD KIT	46	1
41	13033011	DRAWER LOGO		2
42	00537041	TD LOCK LABEL		1
43	00537023	TD PLACE PAPER LABEL		1
44	00537031	TD STOP LABEL		1
45	04115011	HTL-500 GREASE CLEAR		1
46	24047991	TD MAINTENANCE GREASE KIT (NOT SHOWN)	45 (2)	1
47	24076011	TD REPLACEMENT BACK PANEL KIT (ALL PARTS IN BOX)		1
48	24098991	TD TRACK REPAIR KIT STD ARM	6	1

Revised 08/04/2020

TRANSACTION DRAWER WIRING DIAGRAM DATE MAN. 3/05 AND EARLIER VERSION

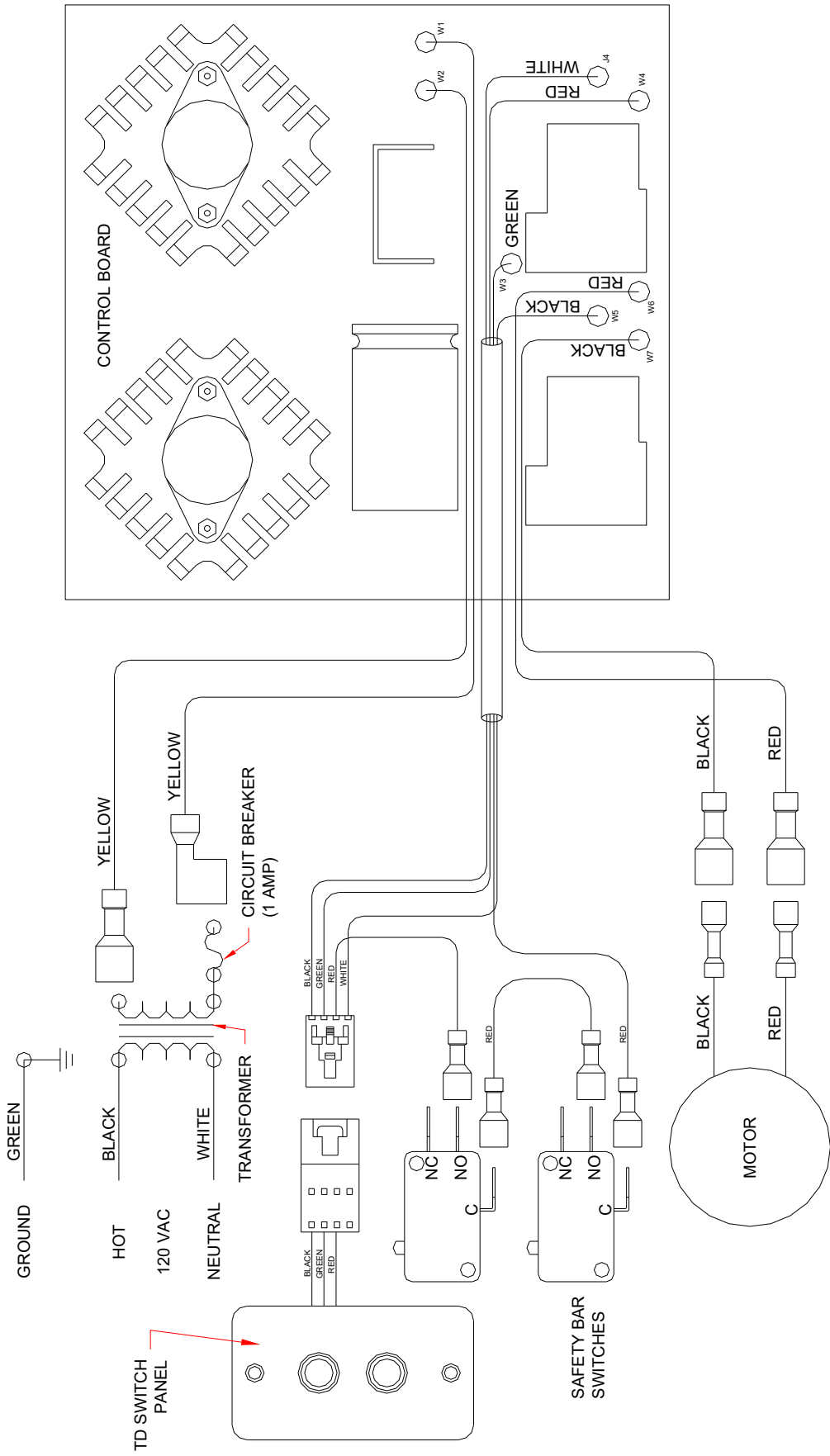

TRANSACTION DRAWER WIRING DIAGRAM DATE MAN. 4/05 THRU 03/20 VERSION

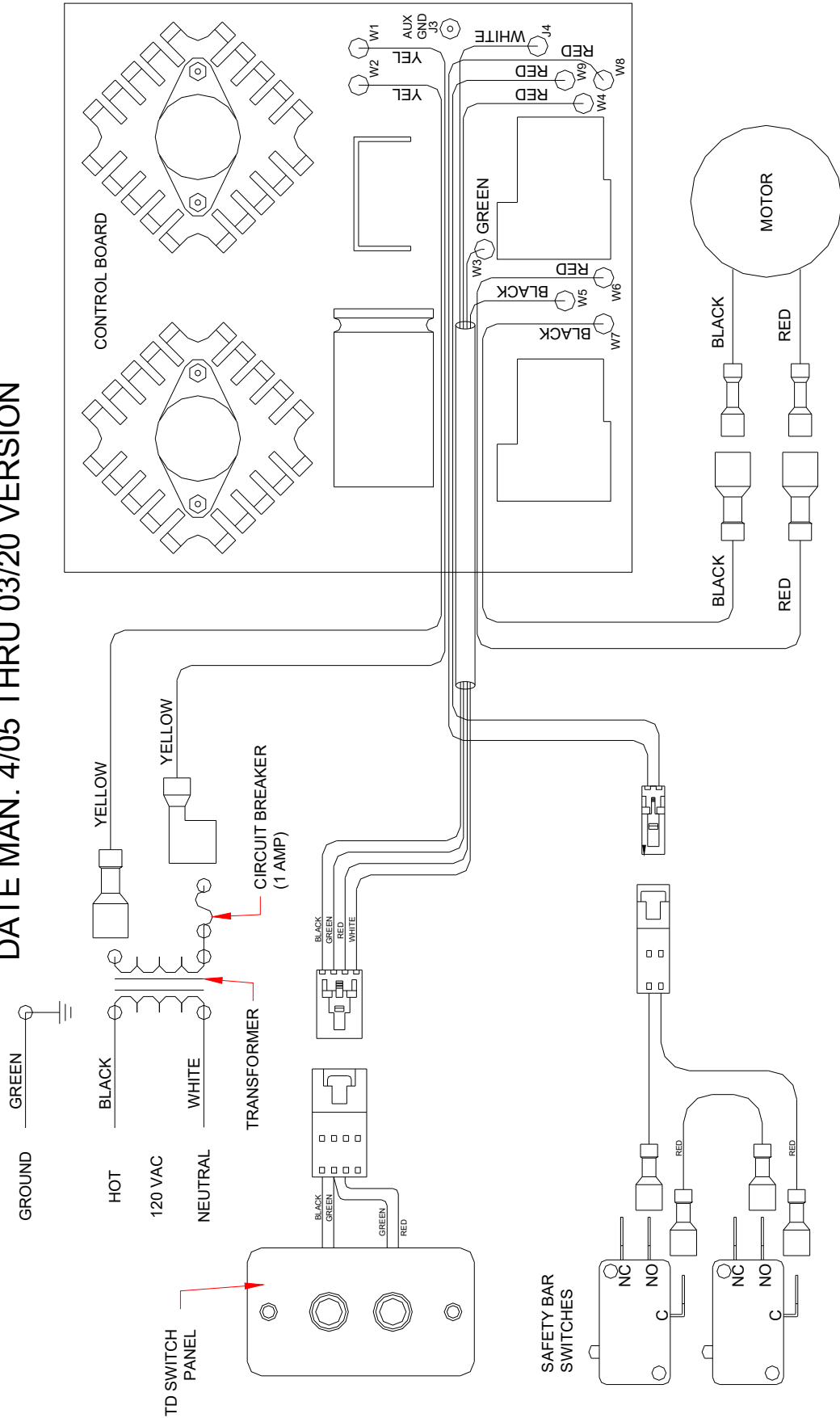

TRANSACTION DRAWER WIRING DIAGRAM CURRENT BLACK BOARD VERSION

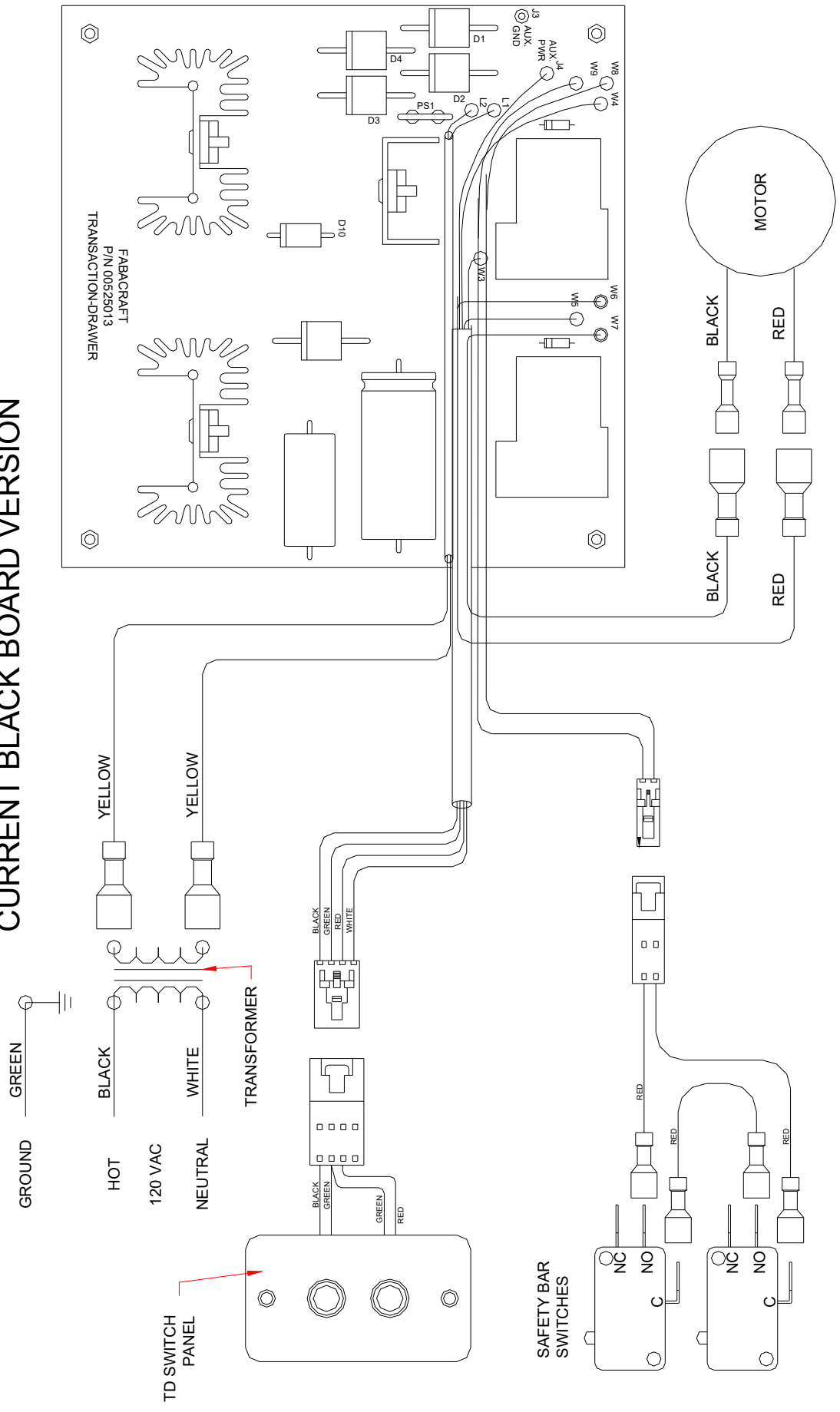

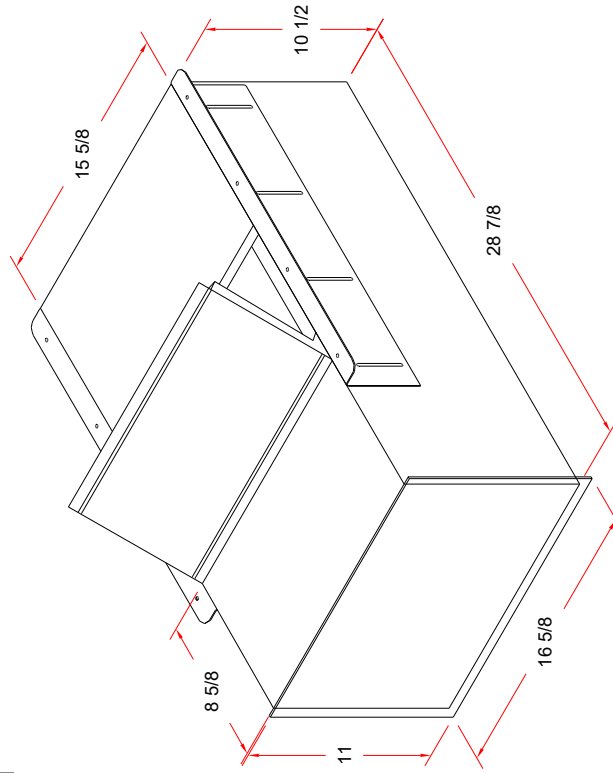
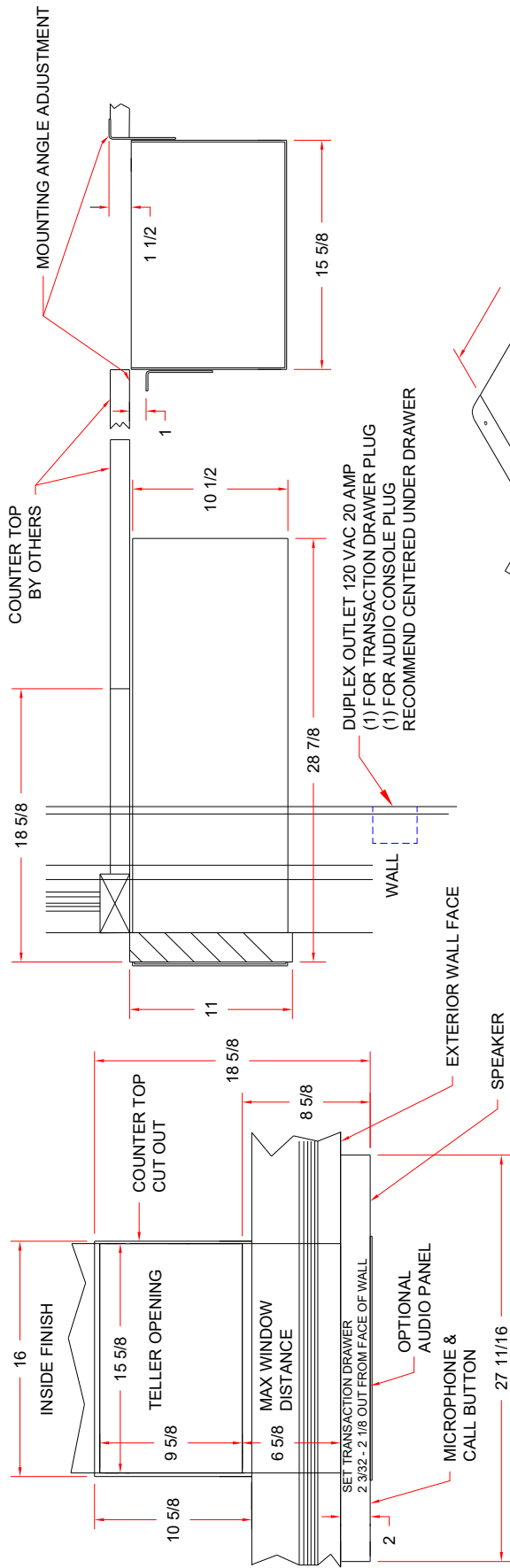

PLAN VIEW

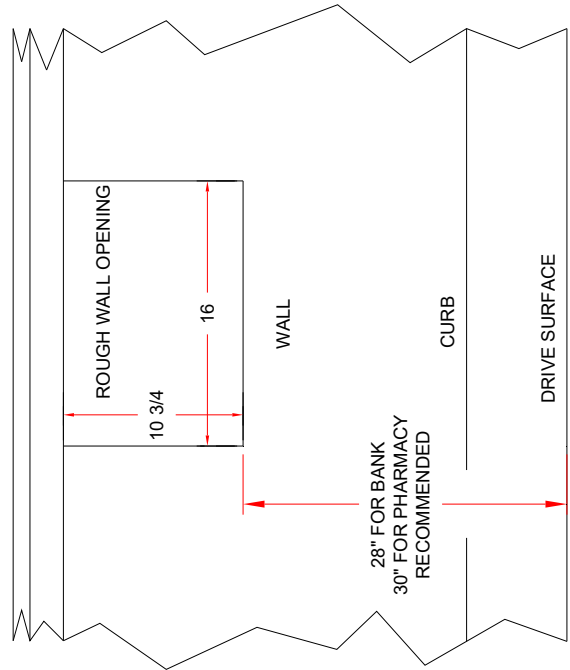

BAVIS TRANSACTION DRAWER DIMENSIONS

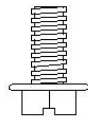

REPLACE THESE HEX HEAD SCREWS

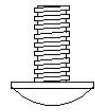

WITH THESE TRUSS HEAD SCREWS

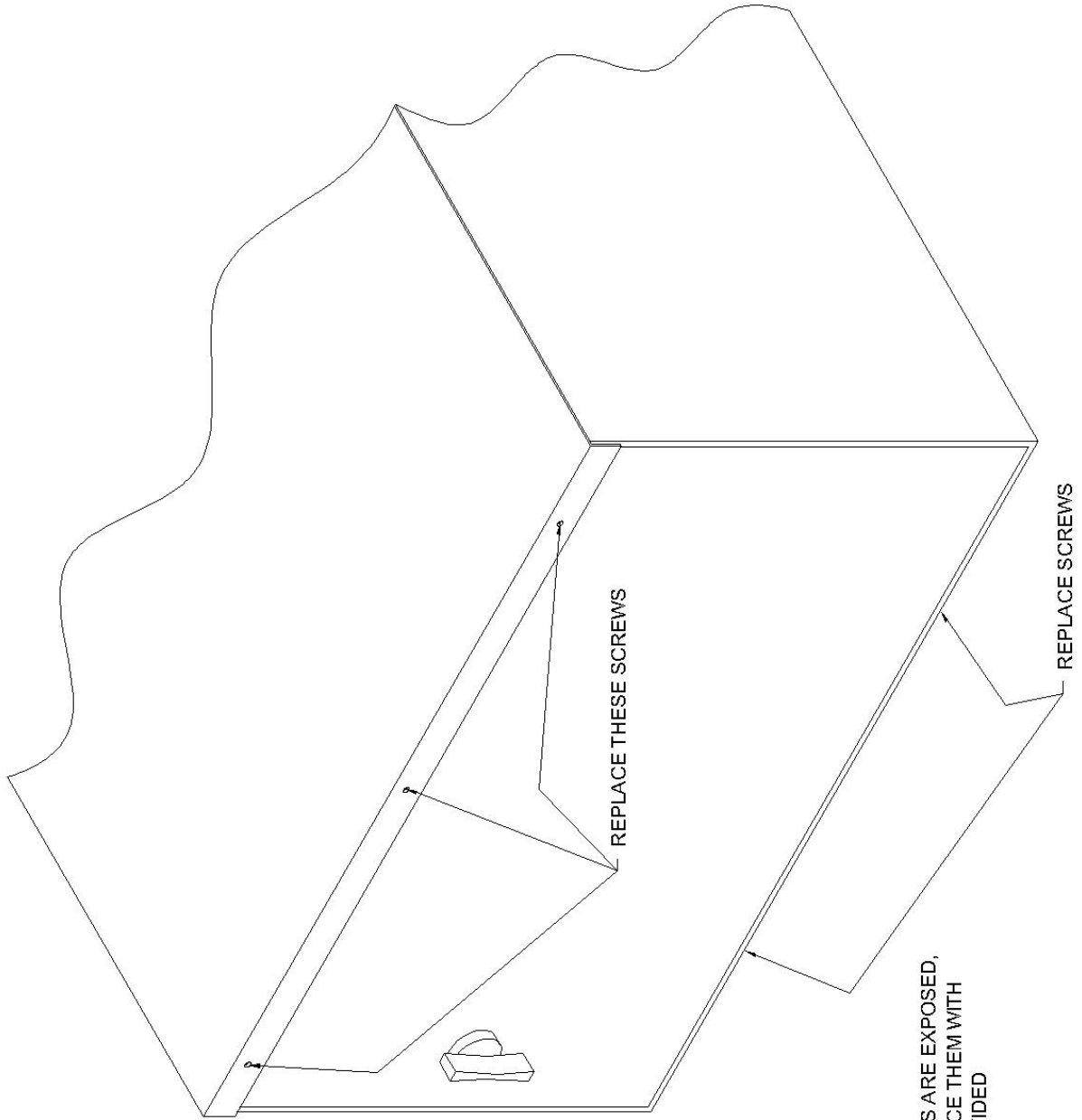

IF BACKPANEL HEX MOUNTING SCREWS ARE EXPOSED, AND COULD CATCH CLOTHING, REPLACE THEM WITH THE #8-32 TRUSS HEAD SCREWS PROVIDED

USE ONLY GREASE SUPPLIED BY E.F. BAVIS P/N 04115011 OR P/N 24047991 MAINTENANCE GREASE KIT

DO NOT CLEAN WITH SOLVENTS.
WIPE ALL AREAS WITH A CLEAN,
DRY CLOTH BEFORE LUBRICATING.

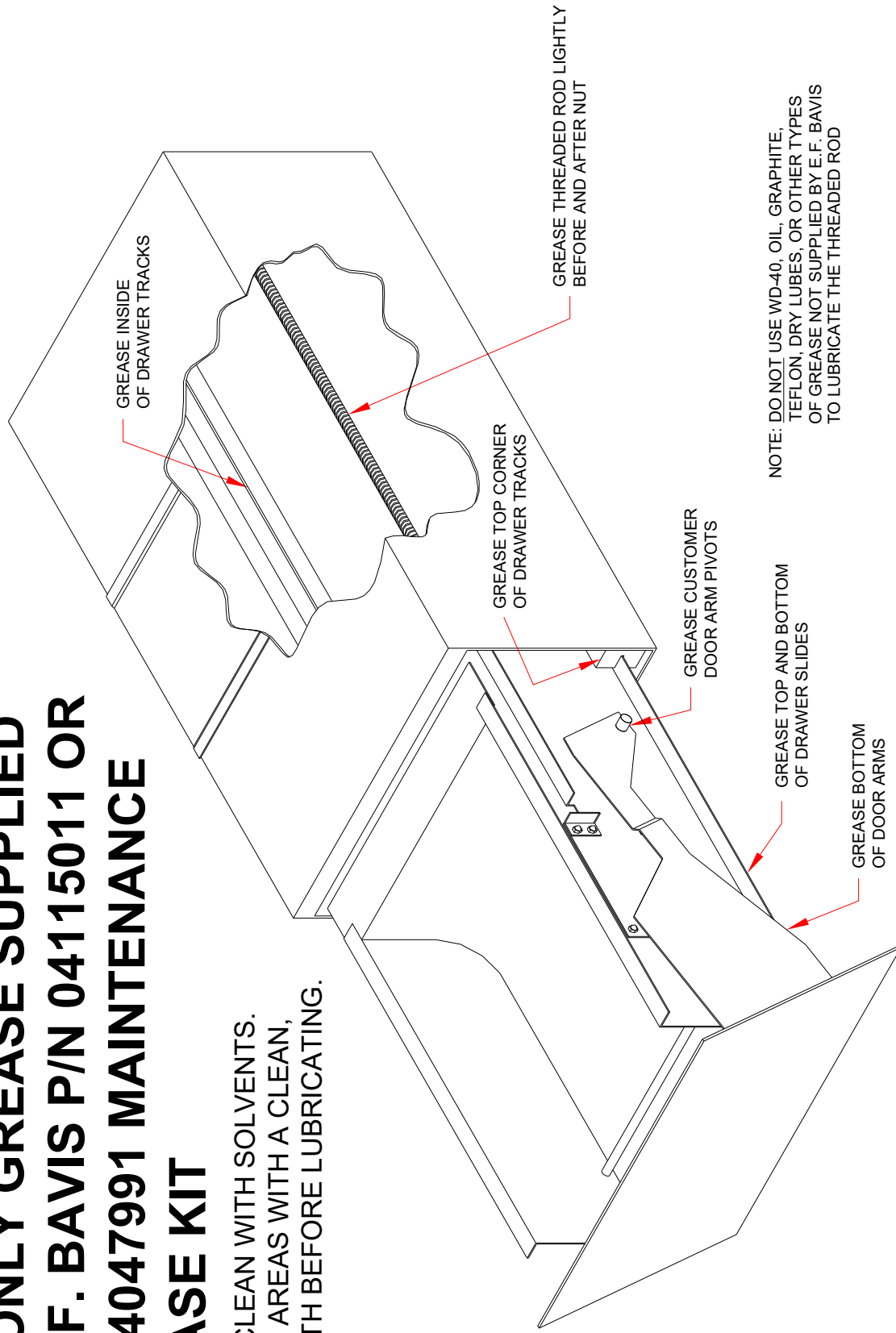

NOTE: DO NOT USE WD-40, OIL, GRAPHITE,
TEFLON, DRY LUBES, OR OTHER TYPES
OF GREASE NOT SUPPLIED BY E.F. BAVIS
TO LUBRICATE THE THREADED ROD

Revisions:

ECN	Date
3182	11/18/2002
3634	02/17/2003
3853	03/31/2003
4649	10/23/2003
7999	12/13/2006
8144	01/26/2007
8848	09/06/2007
10530	04/08/2009
10805	07/09/2009
11010	10/13/2009
12439	03/15/2011
13151	11/15/2011
14148	12/10/2012
15739	09/03/2014
16118	02/24/2015
18391	04/19/2017
18862	11/27/2017
21426	08/04/2020
22511	04/02/2022

