

SECTION A-A
SCALE 1 : 2

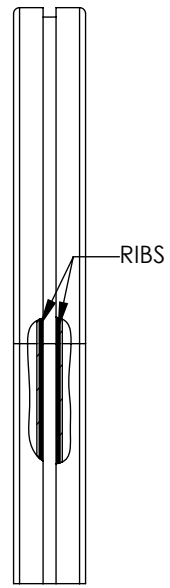
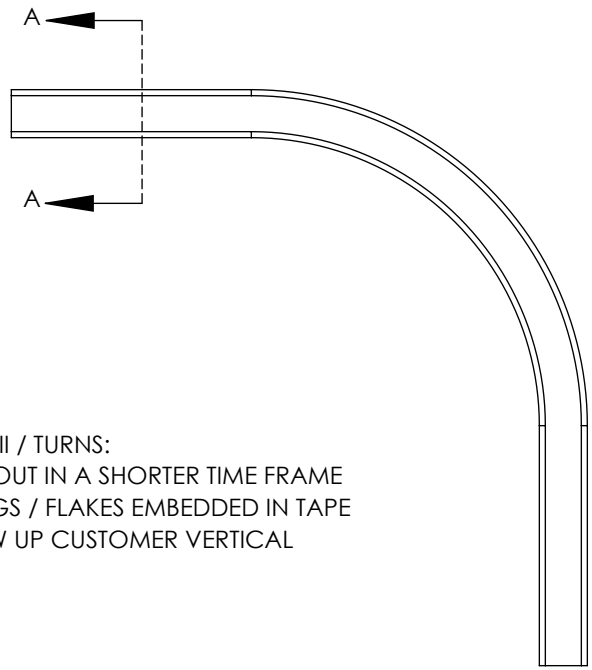

SYMPTOMS OF WORN RADII / TURNS:
 DRIVE TAPE WEARS OUT IN A SHORTER TIME FRAME
 ALUMINUM SHAVINGS / FLAKES EMBEDDED IN TAPE
 CARRIER RUNS SLOW UP CUSTOMER VERTICAL

PROPRIETARY

THIS DOCUMENTATION AND INFORMATION CONTAINED ARE THE SOLE PROPERTY OF E.F. BAVIS & ASSOC., INC. IT SHALL BE RETURNED UPON REQUEST AND SHALL NOT BE REPRODUCED IN WHOLE OR IN PART, OR DISCLOSED TO ANYONE ELSE, OR USED, WITHOUT WRITTEN CONSENT OF E.F. BAVIS & ASSOC., INC.

B BAVIS FABACRAFT
 201 GRANDIN RD.
 MAINEVILLE, OH 45039
 T: 513.677.0500
 F: 513.677.0552
 WWW.BAVIS.COM

SIGNATURES		DATE	TITLE
DRAWN MJC		08/16/22	WORN RADIUS INSPECTION ILLUSTRATION
CHECKED RCN		08/16/22	
ENGR.			
DIMENSIONS ARE IN INCHES		TOLERANCE UNLESS OTHERWISE SPECIFIED:	
UNLESS OTHERWISE SPECIFIED		DECIMAL ± 0.015	
ECN 22530		FRACTION ± N/A	SIZE A
		ANGULAR ± N/A	DRAWING NO. 00726012
			SHEET 1 OF 1